



# High-Performance DisplayPort Gen2 2-1 Multiplexer

## CBTL06DP212EE

Last Updated: Apr 27, 2023

CBTL06DP212 is a high performance multi-channel Generation 2 multiplexer meant for DisplayPort (DP) v1.2, v1.1a or Embedded DisplayPort applications operating at data rate of 1.62 Gbit/s, 2.7 Gbit/s or 5.4 Gbit/s. It is designed using NXP® proprietary high-bandwidth pass-gate technology and it can be used for 1 : 2 switching or 2 : 1 multiplexing of four high-speed differential AC-coupled DP channels. Further, it is capable of switching/multiplexing of Hot Plug Detect (HPD) signal as well as Auxiliary (AUX) and Display Data Channel (DDC) signals. In order to support GPUs/CPUs that have dedicated AUX and DDC I/Os, CBTL06DP212 provides an additional level of multiplexing of AUX and DDC signals delivering true flexibility and choice.

A typical application of CBTL06DP212 is on motherboards where one of two GPU DisplayPort sources needs to be selected to connect to a DisplayPort sink device or connector. A controller chip selects which path to use by setting a select signal HIGH or LOW. Due to the bidirectional nature of the signal paths, CBTL06DP212 can also be used in the reverse topology, e.g., to connect one display source device to one of two display sink devices or connectors.

## CBTL06DP212 Block Diagram Block Diagram

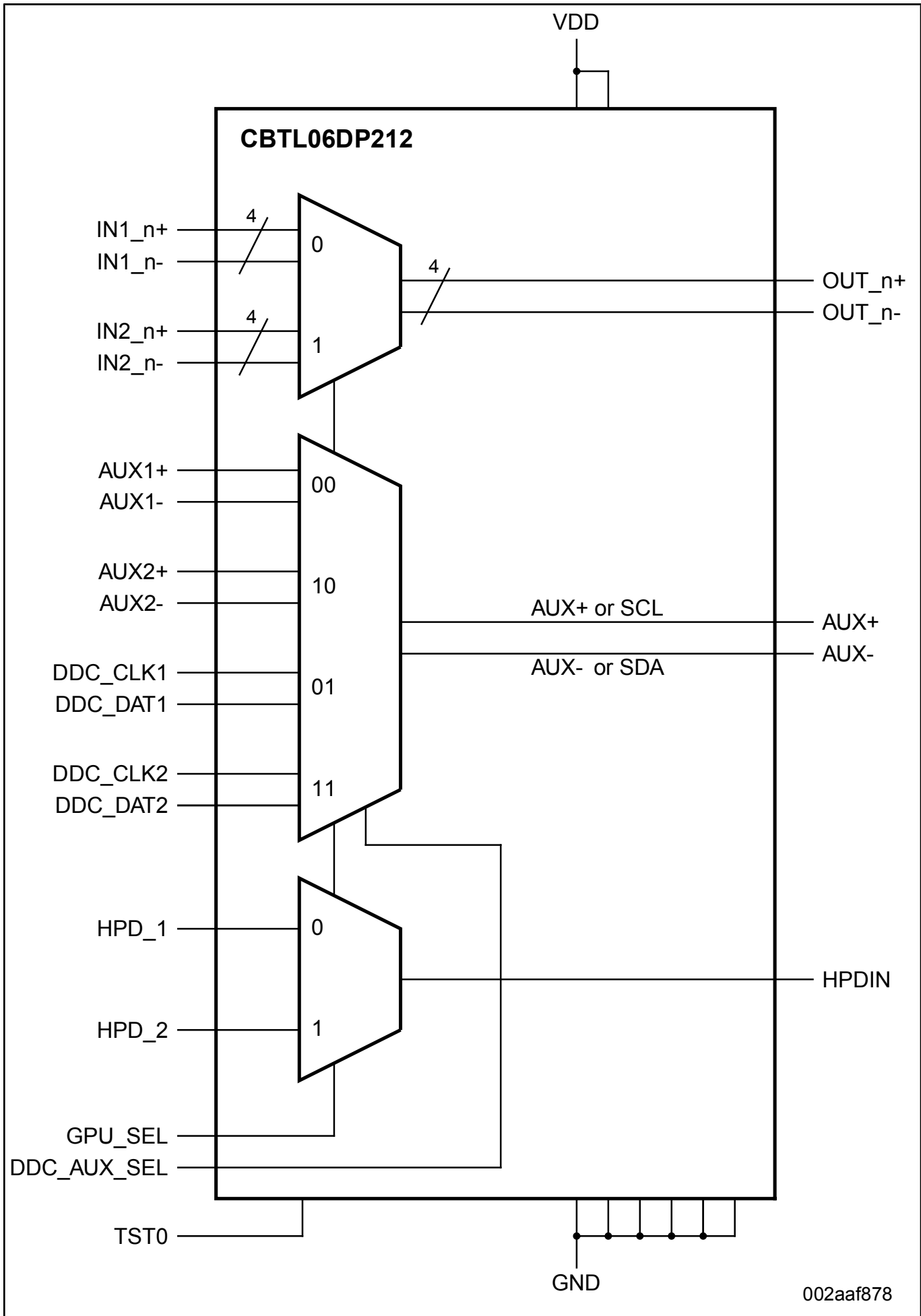

View additional information for [High-Performance DisplayPort Gen2 2-1 Multiplexer](#).

**Note:** The information on this document is subject to change without notice.

---

**[www.nxp.com](http://www.nxp.com)**

NXP and the NXP logo are trademarks of NXP B.V. All other product or service names are the property of their respective owners. The related technology may be protected by any or all of patents, copyrights, designs and trade secrets. All rights reserved. © 2024 NXP B.V.