



# MCUXpresso SDK for Motor Control

## MCUXPRESSO-SDK-MOTOR-CONTROL

Last Updated: Sep 30, 2024

The MCUXpresso SDK includes multiple example projects with motor control. The example description document and link to MCUXpresso SDK Builder for corresponding SDK package is available in the product catalog table on this page.

The Motor Control middleware provides application examples for following motor types:

- PMSM (permanent magnet synchronous motors) - field-oriented (sinusoidal) control
- BLDC (brushless DC) motors - field-oriented (sinusoidal) or six-step (trapezoidal) control
- ACIM (AC induction motor) - field-oriented (sinusoidal) control

### 3-Phase Brushless DC Motor Control Block Diagram Block Diagram

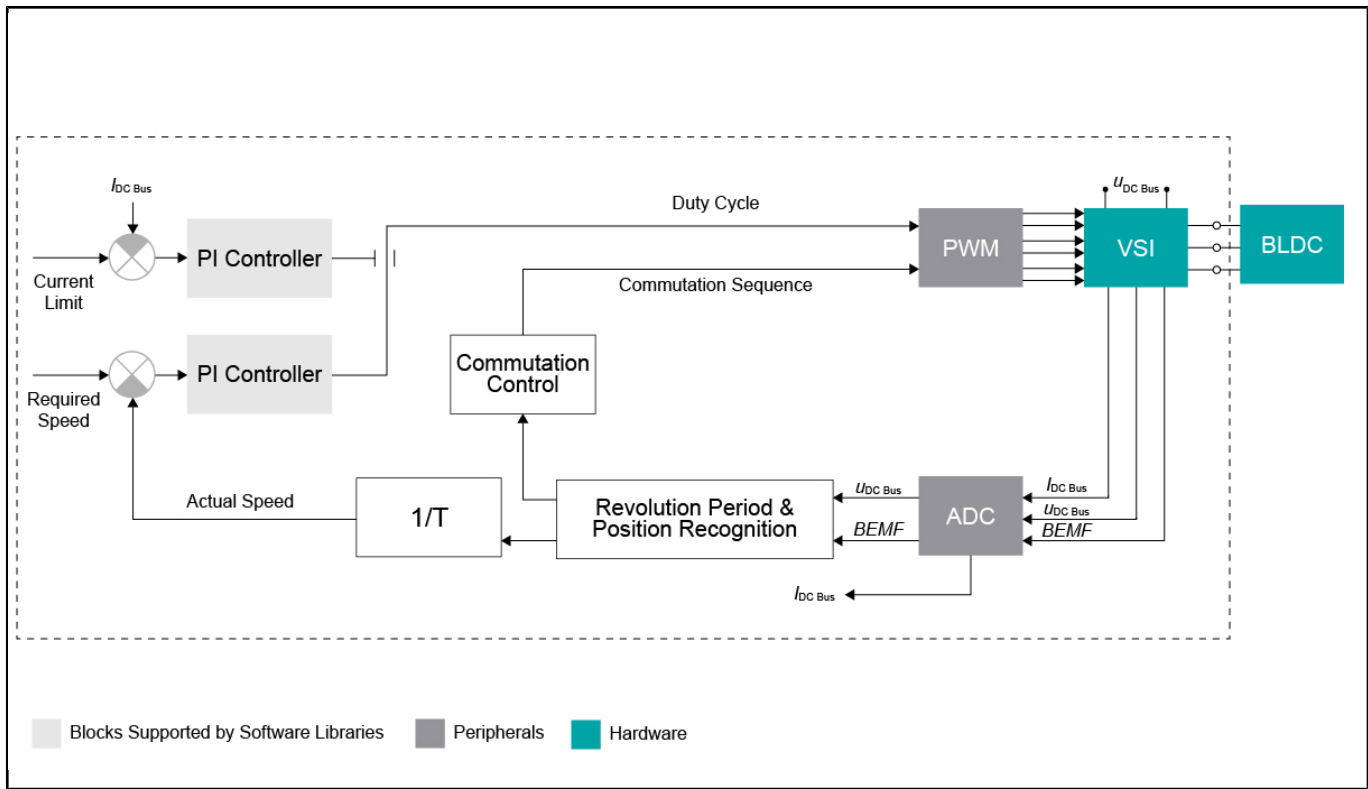

### 3-Phase PMSM Sensorless Control Block Diagram Block Diagram

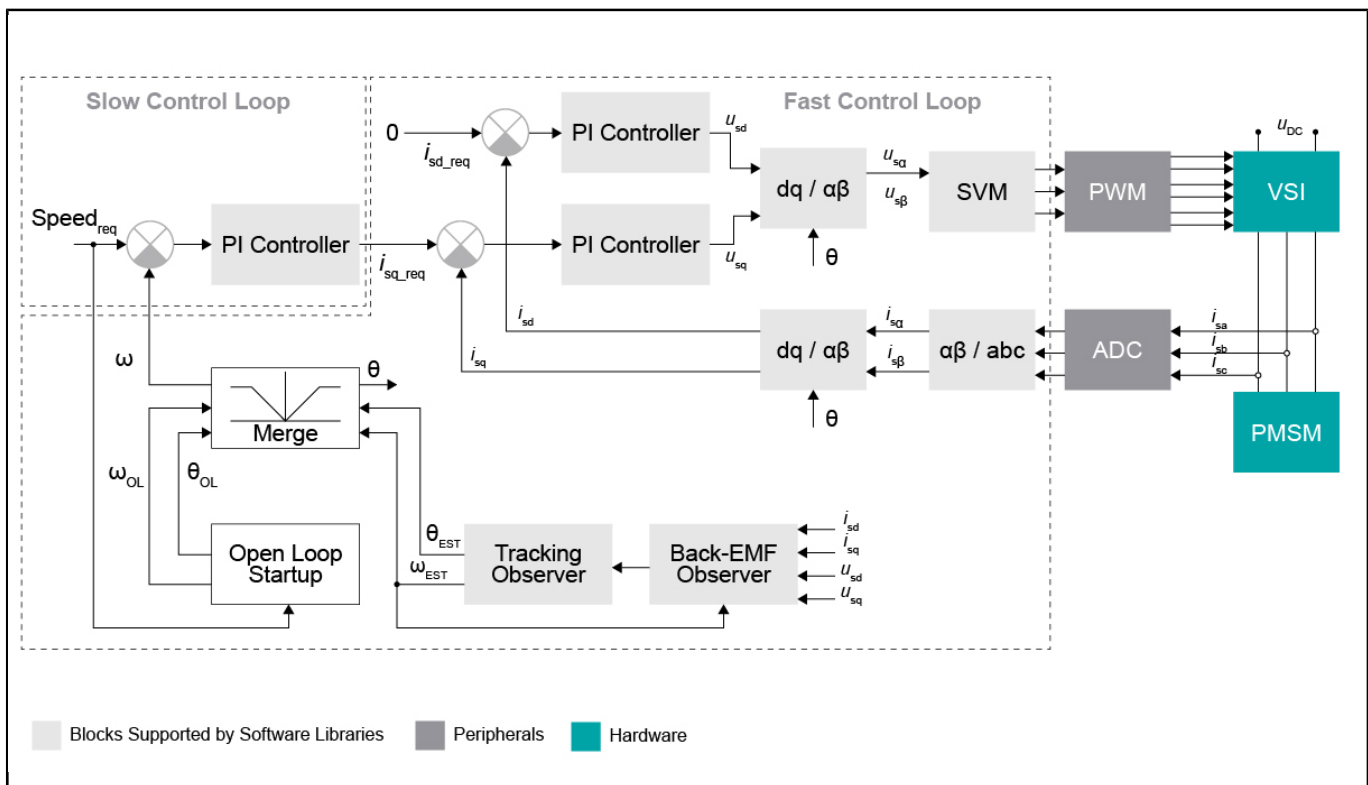

### 3-Phase AC Induction Motor Control Block Diagram Block Diagram

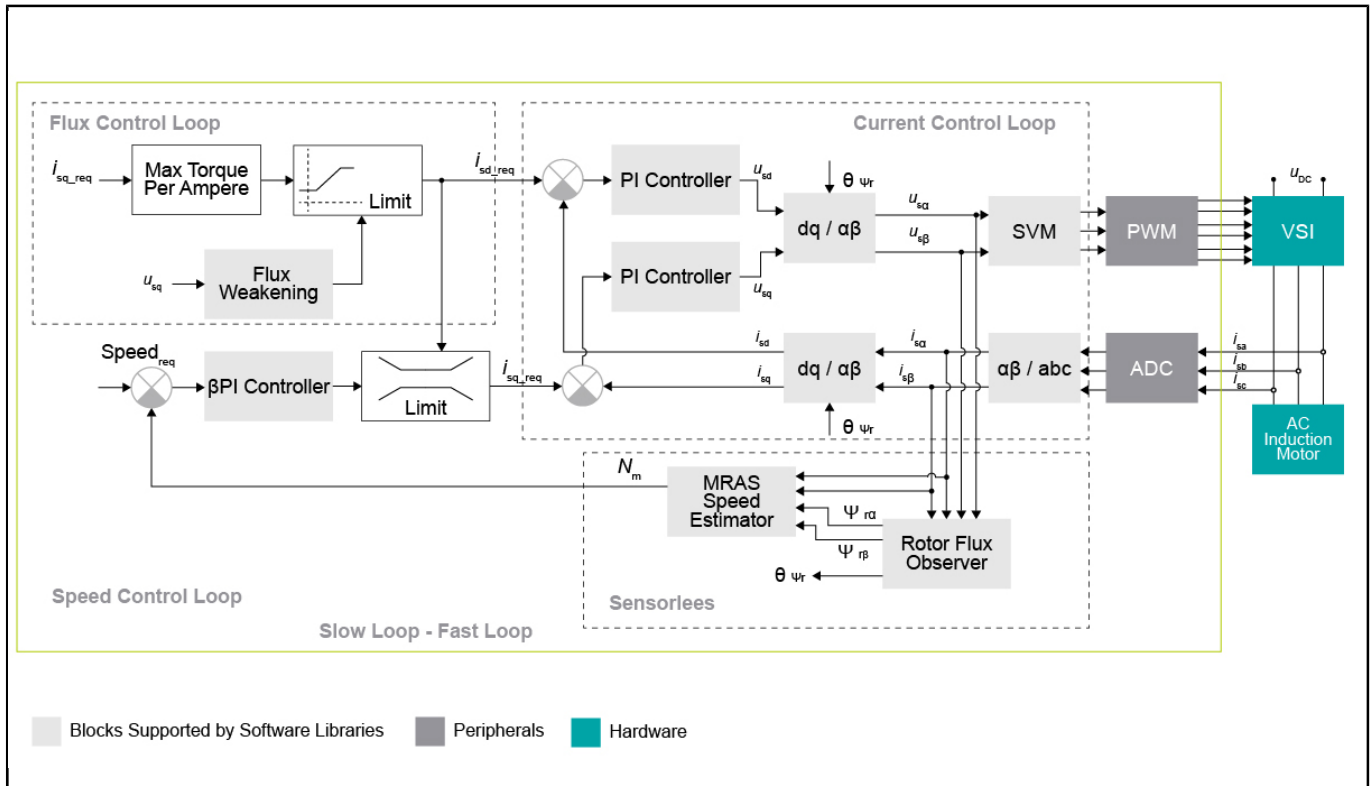

View additional information for [MCUXpresso SDK for Motor Control](#).

**Note:** The information on this document is subject to change without notice.

[www.nxp.com](http://www.nxp.com)

NXP and the NXP logo are trademarks of NXP B.V. All other product or service names are the property of their respective owners. The related technology may be protected by any or all of patents, copyrights, designs and trade secrets. All rights reserved. © 2024 NXP B.V.