



QorIQ® P1023/17 Low-End Single- and Dual-Core Communications Processors with Data Path

P1023

Last Updated: Feb 26, 2025

The P1023 and P1017 processors offer the value of integrated high-performance data path offload for networking protocols and dual e500 Power Architecture® cores for application software. The P1023 and P1017 are ideally suited for high-performance enterprise WLAN, fixed routers and security gateway applications. The P1023 device supports a 400–800 MHz performance range, along with advanced security and a rich set of interfaces—all delivered on 45 nm technology for low-power implementation.

The P1023 processor includes a performance-optimized implementation of the QorIQ® data path acceleration architecture (DPAA). This architecture provides the infrastructure to support simplified sharing of networking interfaces and accelerators by multiple CPU cores. The DPAA significantly reduces software overhead associated with high touch packet forwarding operations. Examples of the types of packet processing services this architecture is optimized to support include traditional routing and bridging, firewall, VPN termination for IPsec and MACsec (a standardized form of Ethernet encapsulation that can be used to provide confidentiality).

Freescale QorIQ P1023/17 Communication Processor Block Diagram Block Diagram

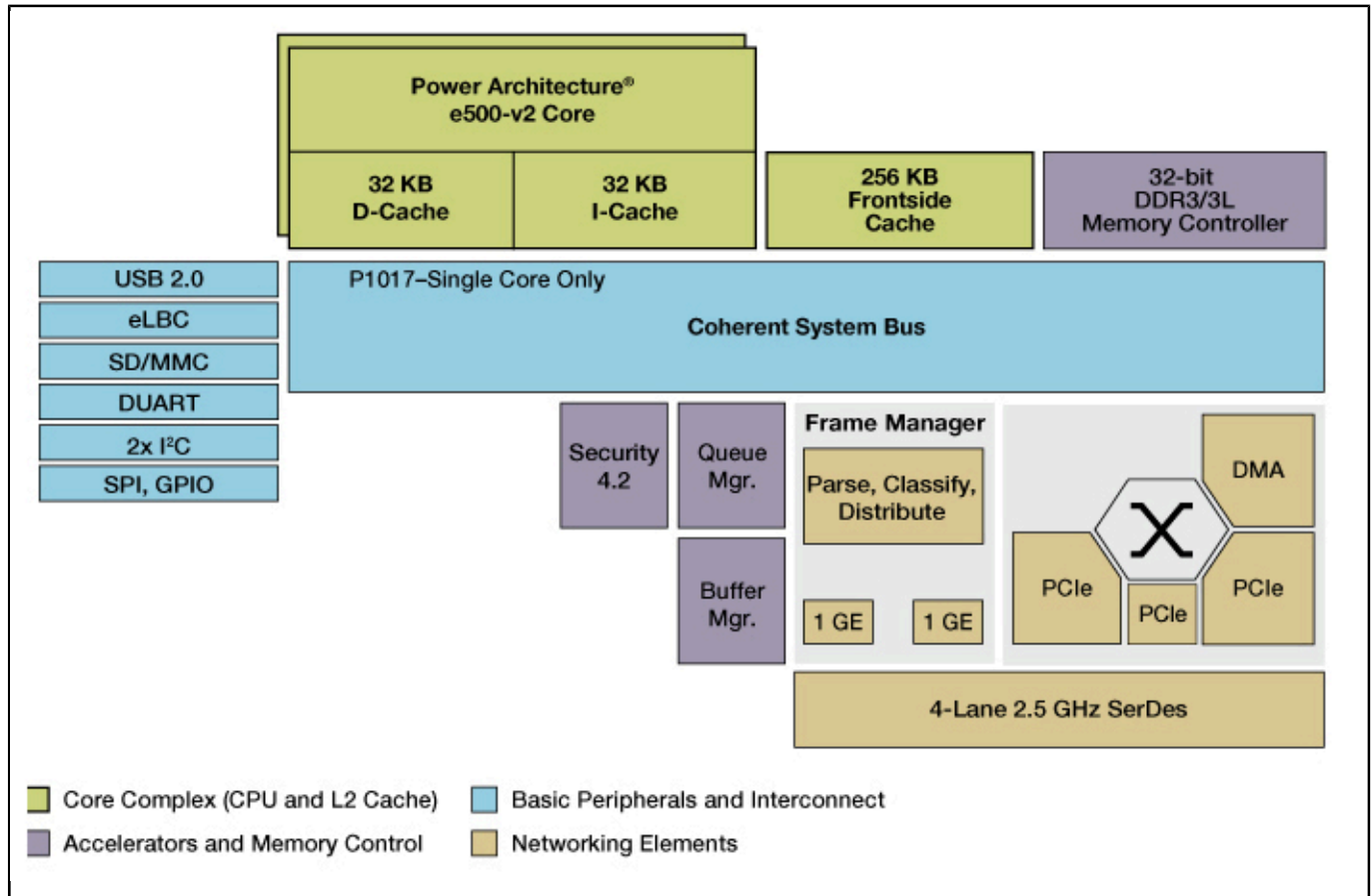

View additional information for [QorIQ® P1023/17 Low-End Single- and Dual-Core Communications Processors with Data Path](#).

Note: The information on this document is subject to change without notice.

www.nxp.com

NXP and the NXP logo are trademarks of NXP B.V. All other product or service names are the property of their respective owners. The related technology may be protected by any or all of patents, copyrights, designs and trade secrets. All rights reserved. © 2025 NXP B.V.