



Totem-Pole Bridgeless PFC Converter

RDPFC56F82748

Last Updated: May 1, 2023

This reference design demonstrates the implementation of a Totem-Pole Bridgeless Power Factor Correction (PFC) using MC56F83783, MC56F81xxx or MC56F82748 Digital Signal Controllers (DSC).

Totem-Pole Bridgeless Block Diagram

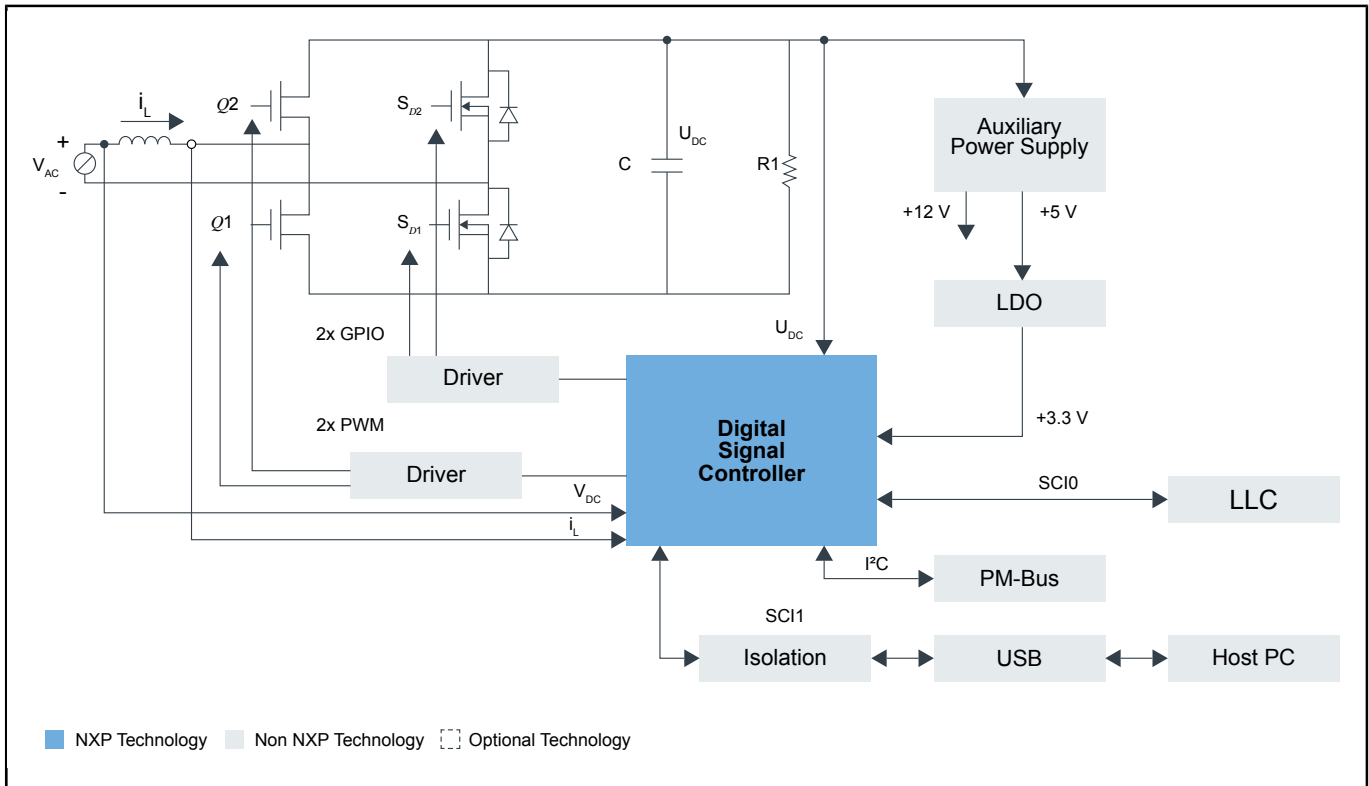

View additional information for [Totem-Pole Bridgeless PFC Converter](#).

Note: The information on this document is subject to change without notice.

www.nxp.com

NXP and the NXP logo are trademarks of NXP B.V. All other product or service names are the property of their respective owners. The related technology may be protected by any or all of patents, copyrights, designs and trade secrets. All rights reserved. © 2024 NXP B.V.