



S12G HVAC Control Reference Design

RDS12GHVAC-1

Last Updated: May 1, 2023

The RDS12GHVAC is a reference design based on the 16-bit S12G ultra-reliable microcontroller, the RDS12GHVAC consists of a central control board with Human-Machine Interface (HMI), a motor control board, flap and blower motors for enabling basic functions of an automotive HVAC using temperature, light, humidity, and air quality sensing interfaces with configurable automatic climate control software algorithm to efficiently control vehicle climate.

RDS12GHVAC-1 Block Diagram

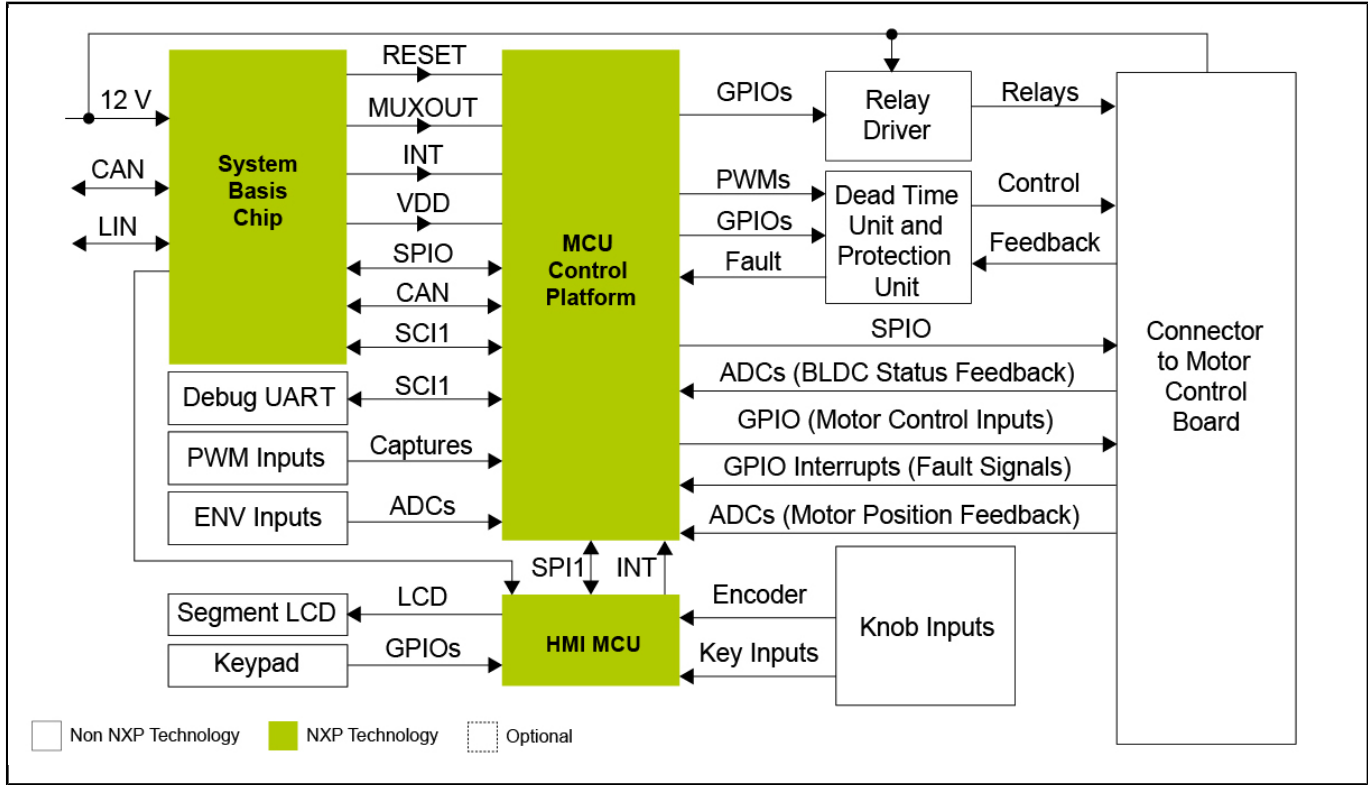

View additional information for [S12G HVAC Control Reference Design](#).

Note: The information on this document is subject to change without notice.

www.nxp.com

NXP and the NXP logo are trademarks of NXP B.V. All other product or service names are the property of their respective owners. The related technology may be protected by any or all of patents, copyrights, designs and trade secrets. All rights reserved. © 2024 NXP B.V.