



Enhanced Octal Universal Asynchronous Receiver/Transmitter (Octal UART)

SCC2698B

Archived

このページには、製造中止（生産終了）となった製品の情報が記載されています。本ページに記載されている仕様および情報は、過去の参考情報です。

Last Updated: Aug 16, 2023

The SCC2698B Enhanced Octal Universal Asynchronous Receiver/Transmitter (Octal UART) is a single chip MOS-LSI communications device that provides eight full-duplex asynchronous receiver/transmitter channels in a single package. It is fabricated with CMOS technology which combines the benefits of high density and low power consumption.

The operating speed of each receiver and transmitter can be selected independently as one of 26 fixed baud rates, a 16X clock derived from a programmable counter/timer, or an external 1X or 16X clock. The baud rate generator and counter/timer can operate directly from a crystal or from external clock inputs. The ability to independently program the operating speed of the receiver and transmitter make the Octal UART particularly attractive for dual-speed channel applications such as clustered terminal systems.

The receiver is quadruple buffered to minimize the potential of receiver overrun or to reduce interrupt overhead in interrupt driven systems. In addition, a handshaking (RTS/CTS) capability is provided to disable a remote UART transmitter when the receiver buffer is full.

The UART provides a power-down mode in which the oscillator is frozen but the register contents are stored. This results in reduced power consumption on the order of several magnitudes. The Octal UART is fully TTL compatible and operates from a single +5 V power supply.

The SCC2698B is an upwardly compatible version of the 2698A Octal UART. In PLCC packaging, it is enhanced by the addition of receiver ready or FIFO full status outputs and

transmitter empty status outputs for each channel on 16 multipurpose I/O pins. The multipurpose pins of the 2698B RIO pins, thus DMA and modem control is provided.

SCC2698BC1A84, SCC2698BE1A84 Block Diagram

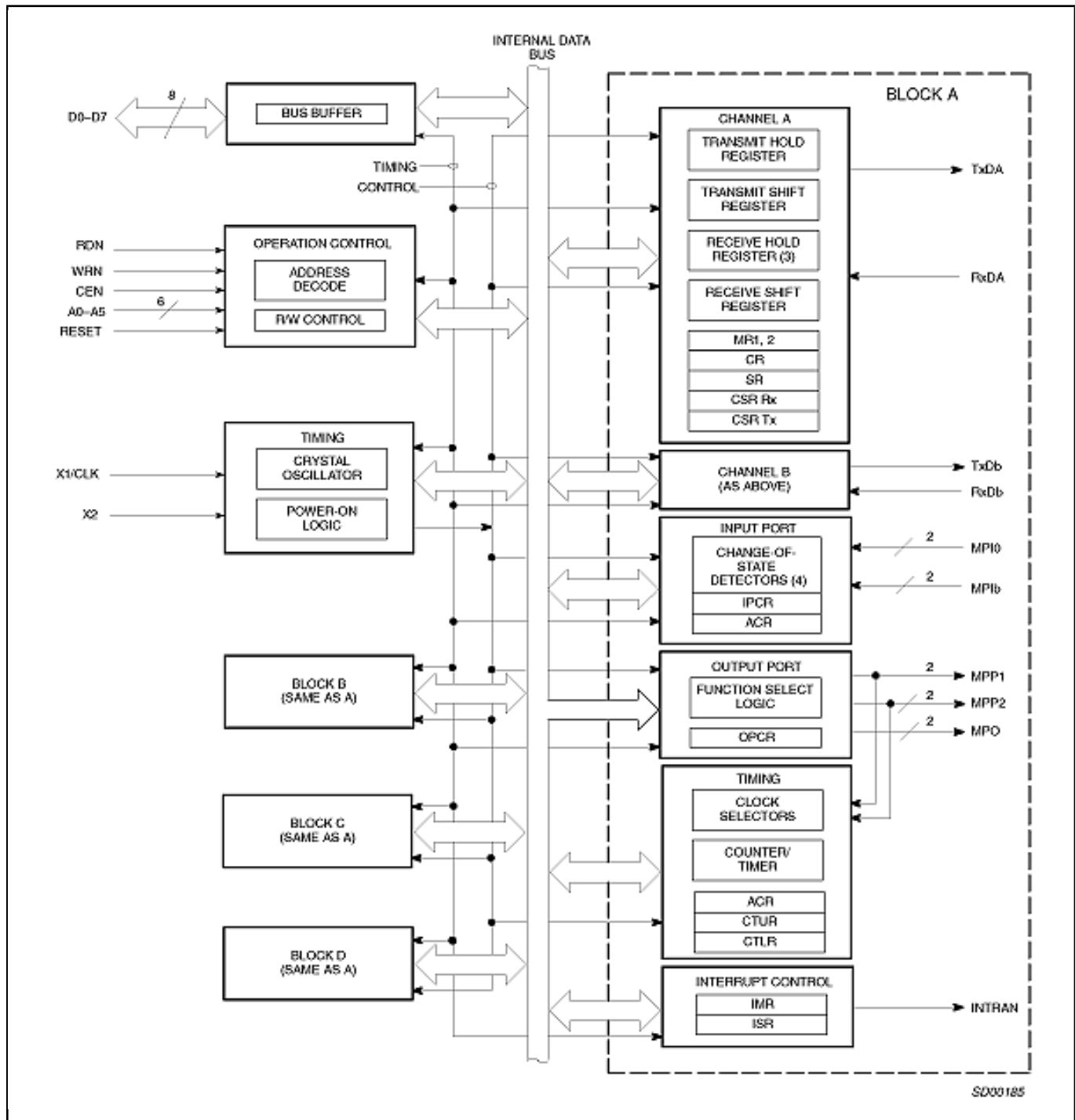

Note: The information on this document is subject to change without notice.

www.nxp.com

NXP and the NXP logo are trademarks of NXP B.V. All other product or service names are the property of their respective owners. The related technology may be protected by any or all of patents, copyrights, designs and trade secrets. All rights reserved. © 2024 NXP B.V.