



Multimedia Applications Processors - Low Power Optimization, Integrated Electronic Paper Display (EPD), Arm® Cortex®-A8 Core

i.MX507

Last Updated: Mar 4, 2025

Building on the market-leading i.MX508 applications processor for eReaders, the i.MX507 processor is the latest addition to Our Arm® Cortex®-A8 product portfolio. The i.MX507 combines a Cortex A8 and an integrated hardware Electronic Paper Display (EPD) controller to drive next generation low power display applications including outdoor signage and kiosks. Together with the companion NXP® power management ICs (PMIC) MC34708 and MMPF0100, customers can drive their next generation EPD designs with the i.MX507 processor.

i.MX507 Multimedia Applications Processor Block Diagram Block Diagram

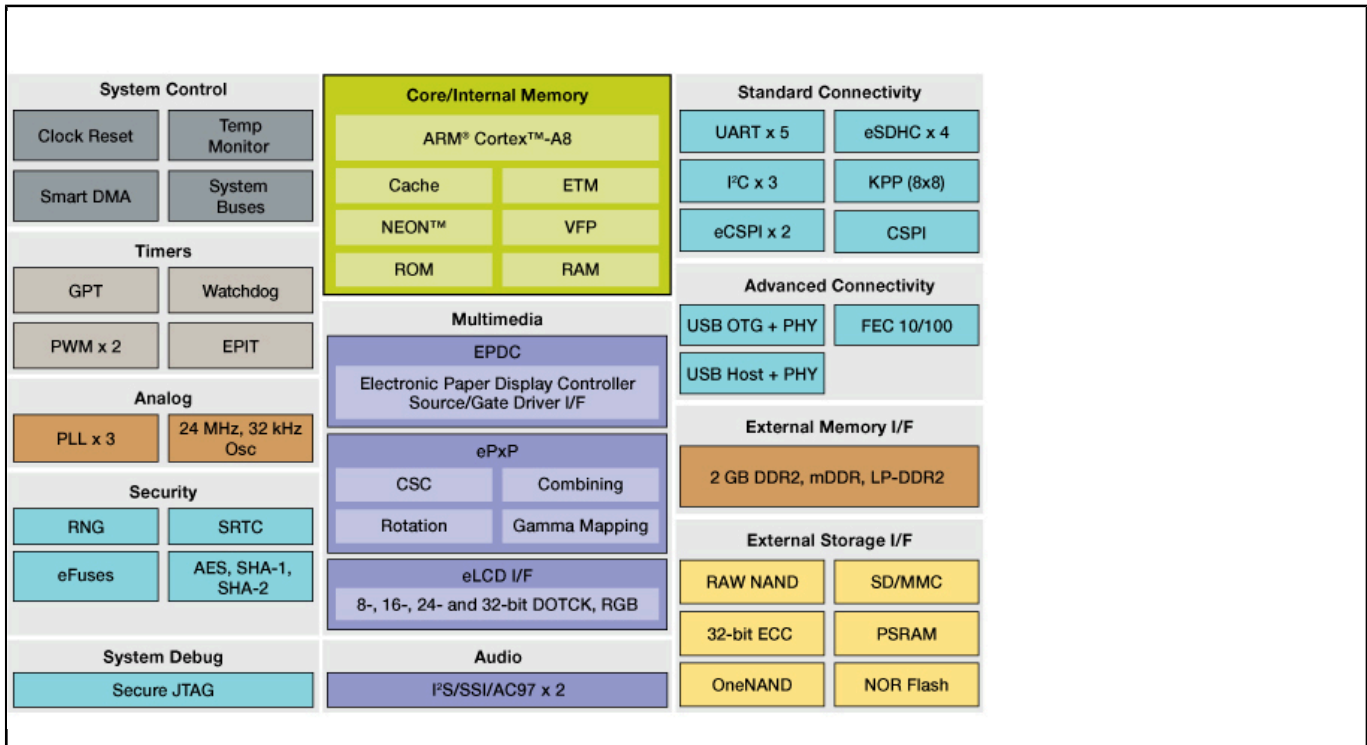

View additional information for [Multimedia Applications Processors - Low Power Optimization, Integrated Electronic Paper Display \(EPD\), Arm® Cortex®-A8 Core](#).

Note: The information on this document is subject to change without notice.

www.nxp.com

NXP and the NXP logo are trademarks of NXP B.V. All other product or service names are the property of their respective owners. The related technology may be protected by any or all of patents, copyrights, designs and trade secrets. All rights reserved. © 2025 NXP B.V.