

AN11501

BFU590G ISM 866 MHz PA design

Rev. 1 — 16 June 2014

Application note

Document information

Info	Content
Keywords	BFU590G, PA, ISM-band, 433MHz 866MHz
Abstract	This document describes an ISM Frequency PA design on BFU590G Starter kit
Ordering info	BFU590G Starter kit OM7966, 12nc 9340 678 75598
Contact information	For more information, please visit: http://www.nxp.com



Revision history

Rev	Date	Description
1	20140616	First publication

Contact information

For more information, please visit: <http://www.nxp.com>

For sales office addresses, please send an email to: salesaddresses@nxp.com

1. Abstract

In this application note an ISM band (industrial, scientific and medical) PA design using a BFU590G transistor from NXP latest wideband transistor range is described. It shows the design, simulation and implementation phases. Together with measurement results, parameters measured over temperature are shown.

The application note (AN) can be a starting point for new design(s), and/or derivative designs.

2. Introduction

The BFU500 transistor family is designed to meet the latest requirements on high frequency applications (up to approximately 2 GHz) such as communication, automotive and industrial equipment.

As soon as fast, low noise analogue up to medium power signal processing is required, combined with medium to high voltage swings the BFU500 transistors are the perfect choice. Due to the high gain at low supply current those types can also be applied very well in battery powered equipment.

Compared to previous Philips / NXP transistor generations and competitor products' improvements on gain, noise and thermal properties are realized. BFU500 transistors are available in various packages.

The transistors are promoted with a full promotion package, called "starter kits" (one kit type per package-type). Those kits include two PCB's (one with grounded emitter, one with emitter degeneration provision), RF connectors, transistors and simulation model parameters required to perform simulations. See the overview of available starter kits in the table below.

Table 1. Customer evaluation kits

	Basic type	Customer evaluation kits
1	BFU520W, BFU530W, BFU550W	OM7960, starter kit for transistors in SOT323 package
2	BFU520A, BFU530A, BFU550A	OM7961, starter kit for transistors in SOT23 package
3	BFU520, BFU530, BFU550	OM7962, starter kit for transistors in SOT143 package
4	BFU520X, BFU530X, BFU550X	OM7963, starter kit for transistors in SOT143X package
5	BFU520XR, BFU530XR, BFU550XR	OM7964, starter kit for transistors in SOT143XR package
6	BFU580Q, BFU590Q	OM7965, starter kit for transistors in SOT89 package
7	BFU580G, BFU590G	OM7966, starter kit for transistors in SOT223 package



Fig 1. BFU590G evaluation boards

3. Requirements

The demonstrator circuit is designed to show the BFU590G capabilities for a 866 MHz ISM PA with strong focus on best possible efficiency.

The goal of the demonstrator circuit was to design a PA optimized for the ISM band meeting following requirements:

Supply Voltage:	8 Volts nominal
Quiescent current:	0 - 10mA at ambient temperature
Gain:	approx. 10dB
P1dB:	>26dBm
Input Return-Loss:	>10dB
Efficiency:	>55%

The design is aimed at low BOM cost and small PCB area, inductors are SMD types (preferable low cost multilayer types) to enable simple tuning to other frequency bands.

4. Design considerations

Power amplifiers are critical components in wireless systems. They consume a substantial percentage of the total power.

Design goals for a power amplifier can be the following:

- High output power for given dissipation budget
- High gain. (having less stages, less material and lower cost)
- High efficiency (saving energy)
- Low distortion (having a linear system and reducing unwanted spurious emissions)
- Good stability (under given circumstances)

In order to achieve maximum power, high efficiency and Gain (close to the maximum available gain), the output impedance has to be close to the optimum loadline.

Designing for maximum output power and efficiency, will compromise for example the gain and input return loss, but this is assumed to be acceptable.

At any time the circuit should be stable, hence during the design phase the K-factor needs to be observed carefully.

5. Design approach

The design starts in the simulation phase, applying the Mextram Model (available at <http://www.nxp.com>). Agilent "Advanced Design System" (ADS) was used for this but other simulation software packages should give equal results. Spice / Gummel Poon models are also available but may give less reliable results in nonlinear performance (P1dB, IP3 etc).

Once simulation results meet the requirements, the circuit is built on a universal Printed Circuit Board (PCB) and evaluated. If measurement results show significant offset from simulated results, fine tuning is required until required performance is met. To achieve better matching between simulations and measurements, the PCB parasitic properties have to be added in the simulation template. Basic knowledge of PA design is assumed, see literature.

Following blocks of passive components can be identified:

- 1) passives for DC biasing
- 2) passives set up collector load
- 3) passives for input matching
- 4) passives required to ensure stable operation

5.1 Simulation steps

Following simulation / design approach can be useful:

- 1) Configure the DC bias set-up, ensuring the I_{cc} is set around desired value.
- 2) Configure the collector load circuit and output matching circuitry, optimizing the output Return Loss (RL).
- 3) Check stability on the bench afterwards.
- 4) Configure the input matching for maximum gain and acceptable input return loss.
- 5) Check stability on the bench afterwards.

Assumptions:

- Realistic passives are used by applying Murata design kit (0603/0805)
- PCB tracks represented by strip-lines

5.2 Implementation / evaluation steps

Following implementation / evaluation steps have been executed:

- 1) Implement simulated design on universal PCB.
- 2) Evaluate PA on output power / efficiency / Gain / matching / Stability at ambient temperature.
- 3) Fine tune passives if required.
- 4) In case significant differences between simulations and measured results are observed, add or modify parasitic properties in the simulation template.
- 5) Measure PA design on RF parameters over temperature.

5.3 Setting up the DC bias circuit

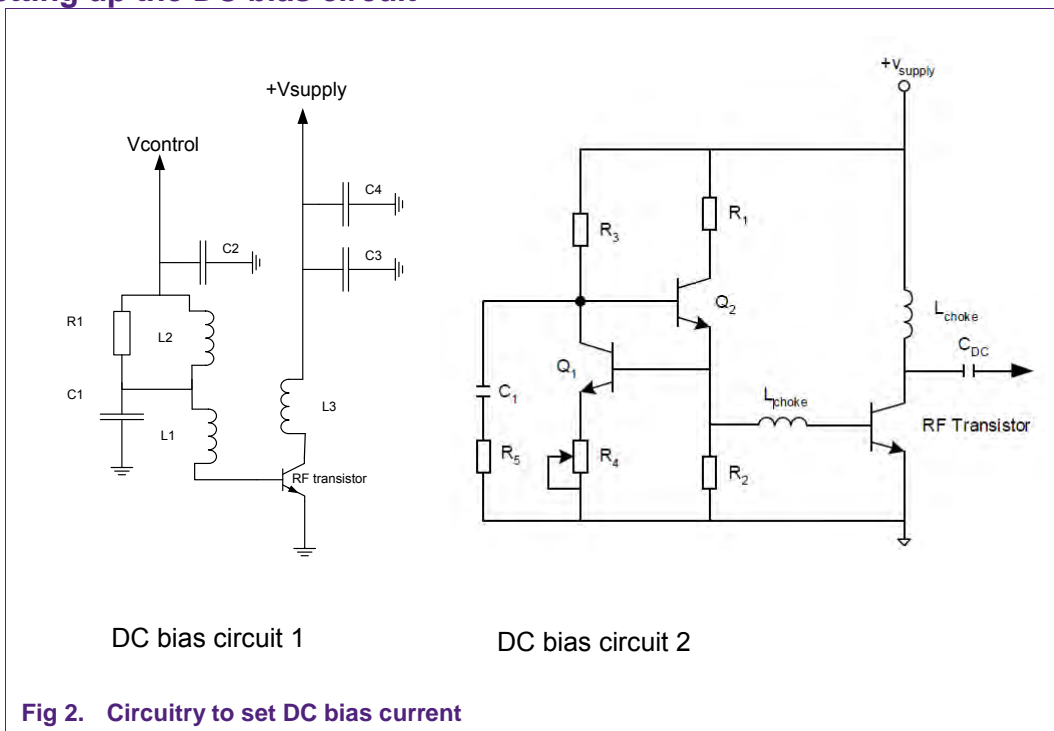

Fig 2. Circuitry to set DC bias current

In a class A amplifier, it is custom to stabilize the operating point by means of an emitter and base resistor. In a RF power amplifier, however, it is preferable to ground the emitter to obtain maximum power gain.

Circuit 1 shows the basic circuit of the bias circuit of an RF power amplifier. Biasing de-coupling networks are designed to present high impedance in the RF band and to have a low impedance in the low frequency band.

Due to proper choice of RF chokes (L1,L2) and bypass capacitors (C1,C2,C3,C4), parasitic oscillations can occur far below the working frequency. The RF chokes combined with the parasitic feedback capacitor (Ccb) can result in a Hartley type of oscillator as shown below. In order to avoid oscillation the inductance values of the chokes should fulfill the condition given in figure 3.

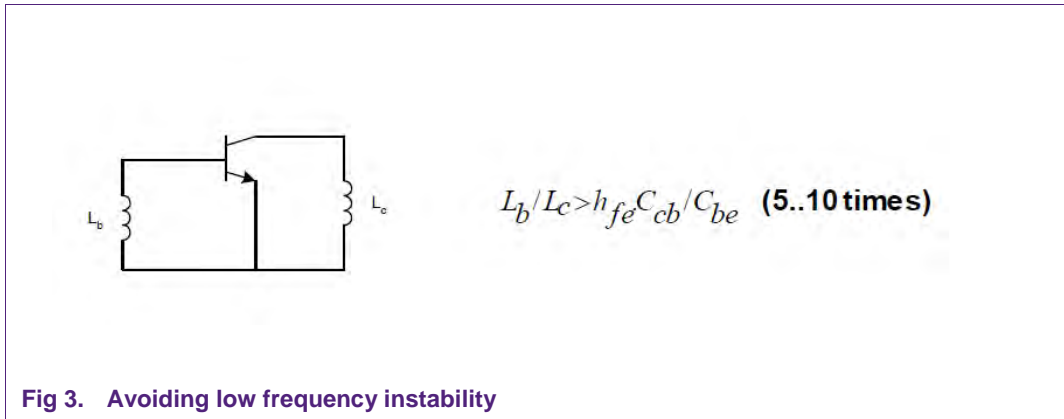

Fig 3. Avoiding low frequency instability

The formula in figure 3 gives the ratio between the collector coil and base coil to avoid low frequency instability.

It is good practice to de-couple the supply points with large capacitors (uF range) to eliminate transients and interactions between other system components on the same supply rail. To avoid LF instability this should not be inserted at the RF de-coupling points. Instead a LF choke (L2) is added to isolate the RF and supply de-coupling points shunted by a resistor (R1).

Circuit 2 shows an example of the class-AB bias circuit. It is required to have a constant VBE, a low output resistance, temperature compensation and low power consumption (efficiency). The bias circuit shown here has large negative feedback. If the base current of the RF power transistor increases the output voltage of the bias circuit will decrease slightly causing the collector current of Q1 to decrease and its collector voltage to increase, counteracting the drop in output voltage. Q1 should have a VBE level which is lower than that of the RF power transistor. R4 compensates for the difference between these two values and used to set the bias level. R1 is incorporated to protect Q2 in case of short circuit in the power transistor. R2 is a preloading resistor used to reduce the base current variation. This circuit can develop parasitic oscillation near 1MHz with highly capacitive loads (such as the base supply bypass capacitors). The series combination C1-R5 can prevent this.

In this AN the circuit on the left has been implemented by using an additional power supply to set the bias current. The circuit on the right is an example of how a bias circuit can be build up.

5.4 Setting up the Simulation circuit in ADS

The configuration below is used for the simulation by ADS. It's a basic circuit amplifier available in the ADS design guide: Amplifier / 1-Tone Nonlinear Simulations / Spectrum, gain, Harmonic Distortion.

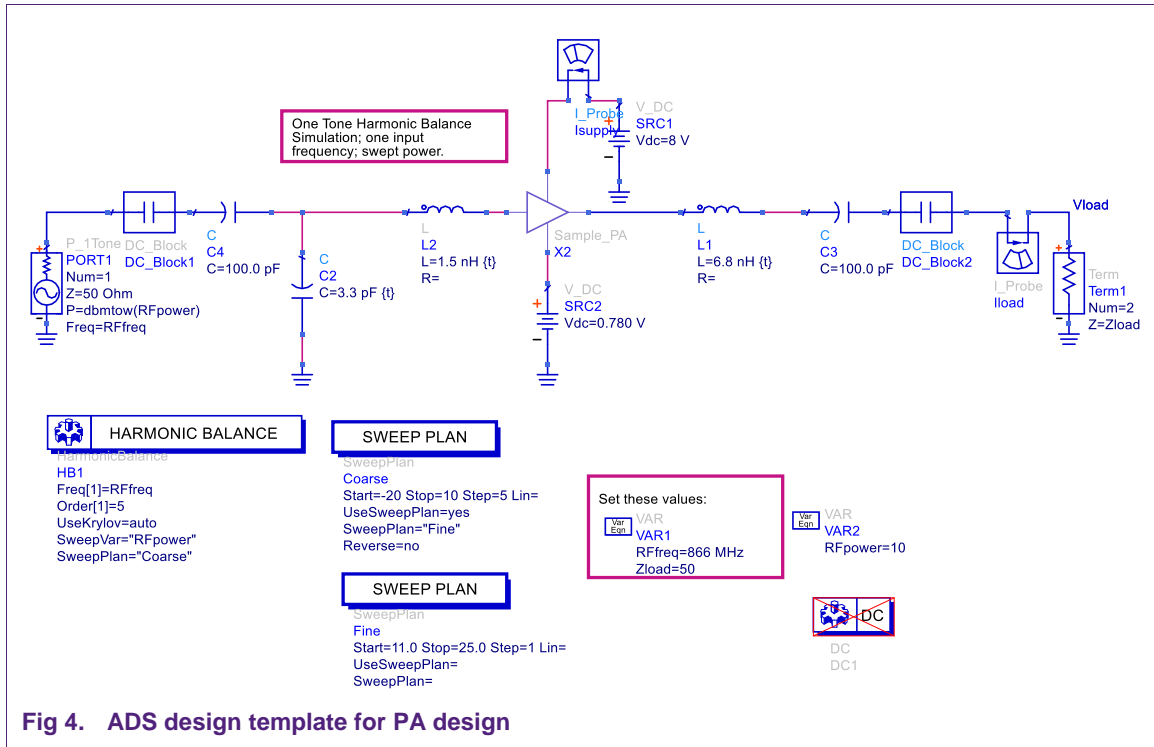

The circuit shows the possibility to choose any frequency, impedance, power range.

5.5 Setting up the collector load

The design has been concentrated to have maximum 1dB compression at 8V power supply having high efficiency and gain.

The load impedance is: $R_L = \frac{(V_{supply} - V_{saturation})^2}{2P_{out}}$

For 0.5W output power the load impedance should be close to 50 Ohm.

Two ways to calculate efficiency:

Efficiency: $\eta_c = \frac{P_{output}}{P_{dc}}$

Power added Efficiency: $\eta_a = \frac{(P_{output} - P_{input})}{P_{dc}} = \eta_c \frac{1}{(1 - \frac{1}{G_p})}$

In this AN the η_c will be used.

The components C2, L2, C1 and L1 (see figure 4) have been used to tune the maximum 1dB compression power, efficiency input return loss and gain in the required frequency band of 433MHz. The bias coil to the base of the transistor was set to 470nH and for the collector was set to 18nH. This ratio meets the low frequency stability rule see figure 3.

There are tradeoffs to make to meet the 1dB compression target:

- Output collector coil (to supply): 18nH. Higher value will reduce the efficiency, a lower value will reduce the gain.
- Output series inductor: 6.8nH. Higher value will decrease the 1dB compression but will improve the efficiency

- The input inductor (L2) and capacitor (C2) can be set to match the input for gain and input return loss.

When going one level deeper in the PA design, the transistor template with it's bias and collector coil is shown, see figure 5.

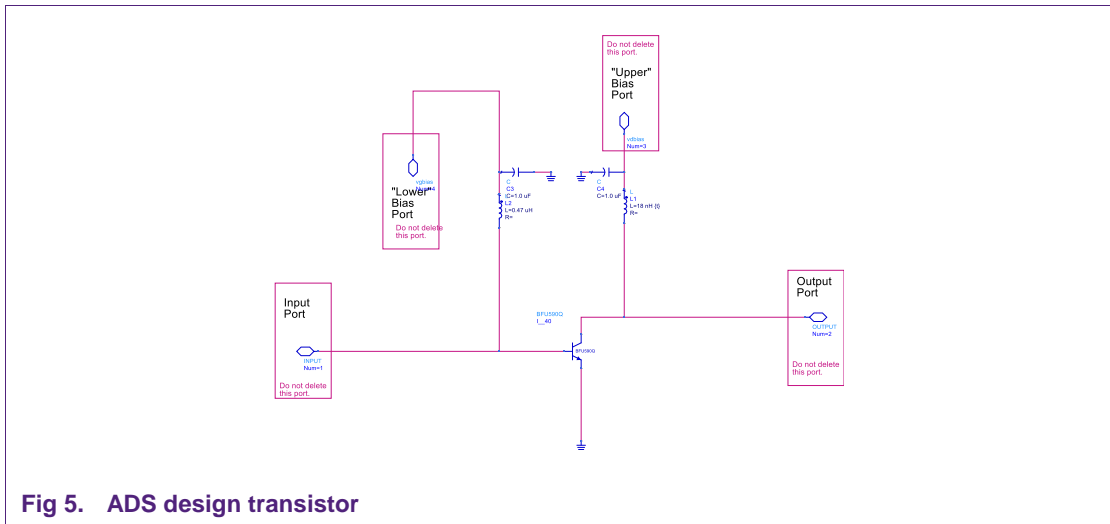

Fig 5. ADS design transistor

The circuit below shows the Idc settings of the circuit:

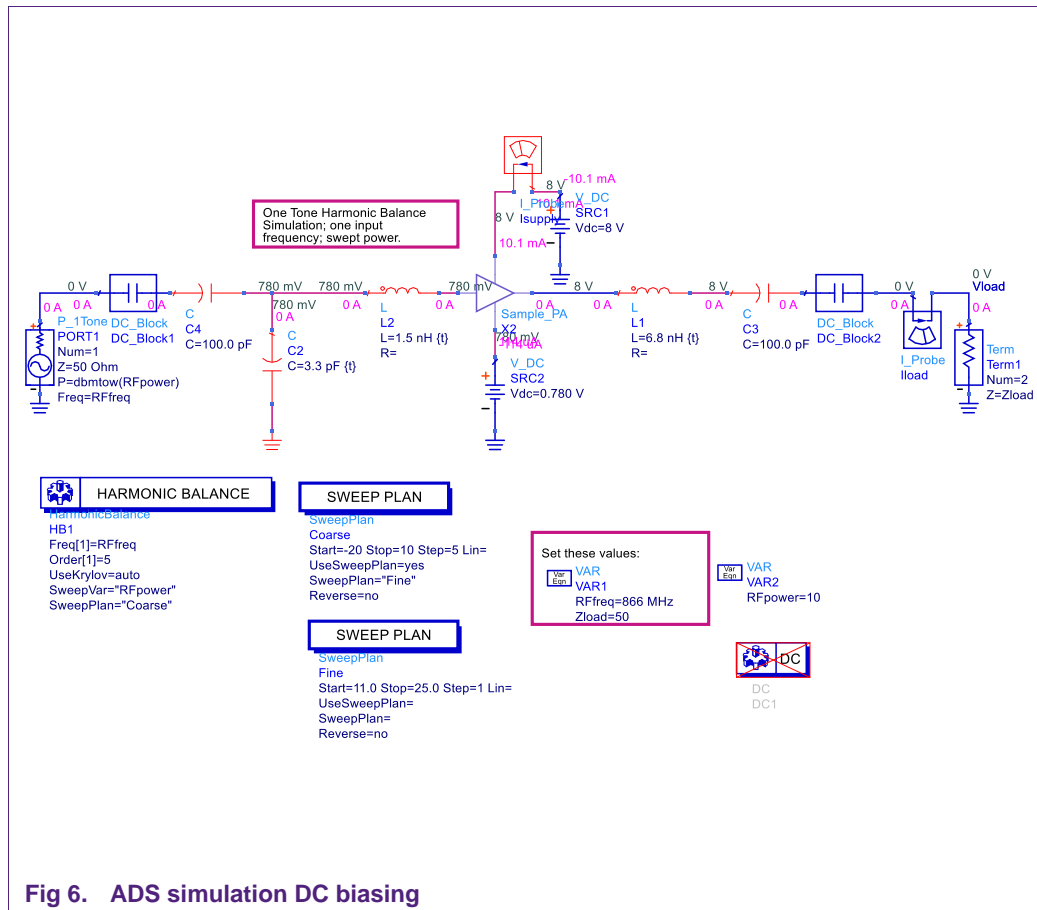

Fig 6. ADS simulation DC biasing

By applying ~0.78V bias at the base of the transistor, the collector current is ~10mA.

Harmonic balance simulation template is used, results to the 5th order are shown below:

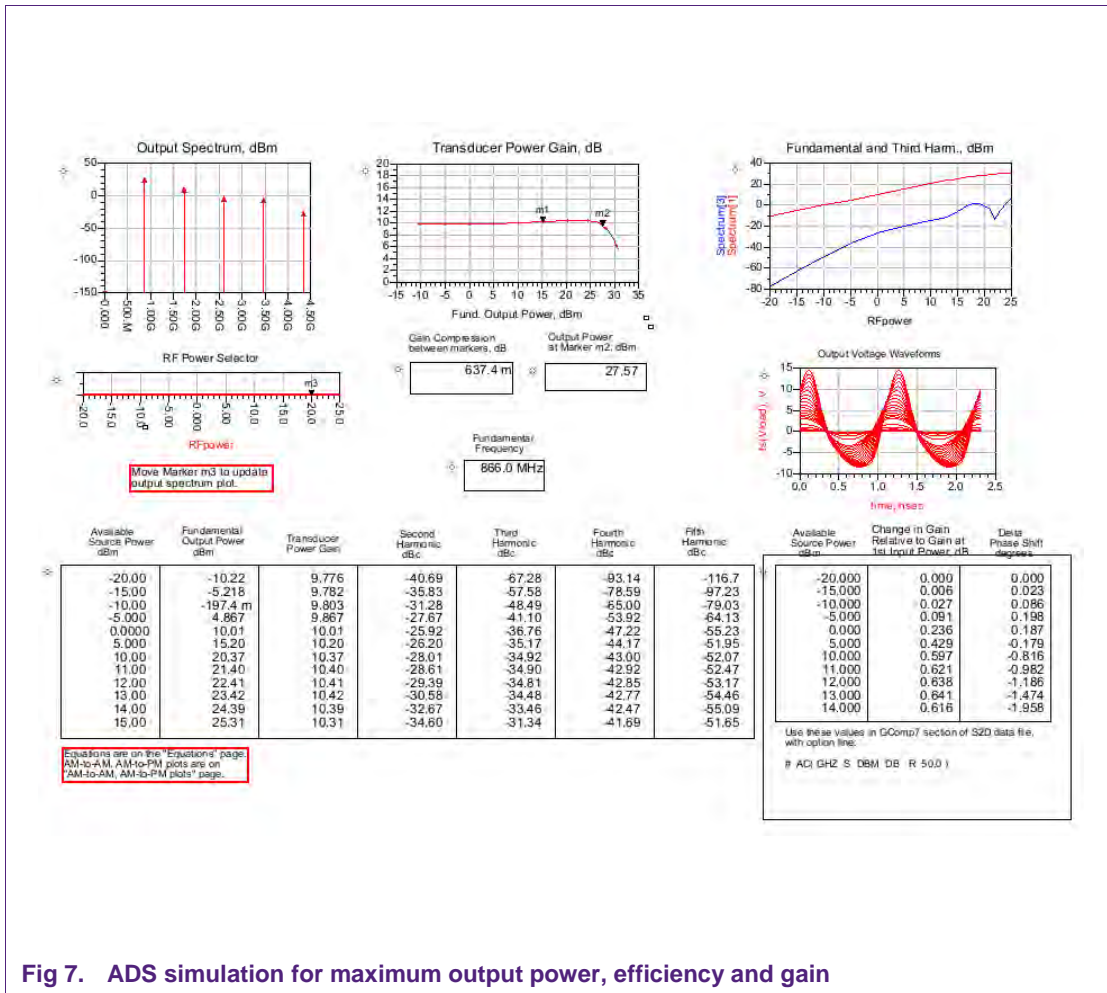
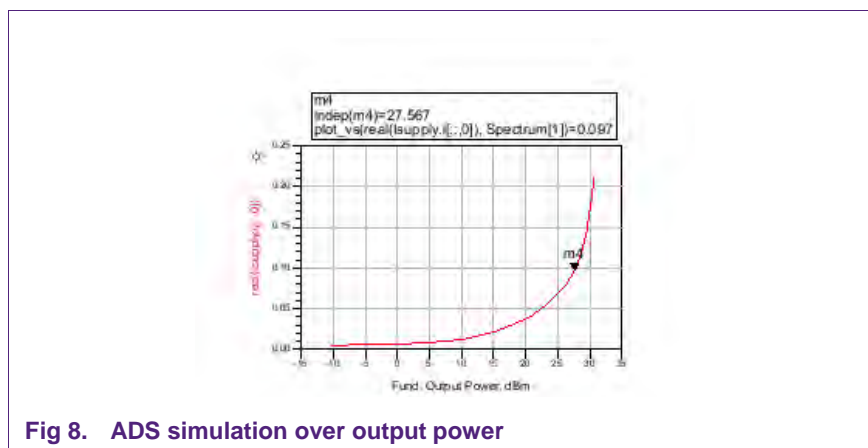

Fig 7. ADS simulation for maximum output power, efficiency and gain

The simulation gives a 1dB compression of 28dBm. The gain is 10dB for low output power. The gain increases slightly to 10.5dB just before reaching the 1dB compression. The harmonic content of the output signal is also given in the table.

In the graph below the Idc over output power is shown.



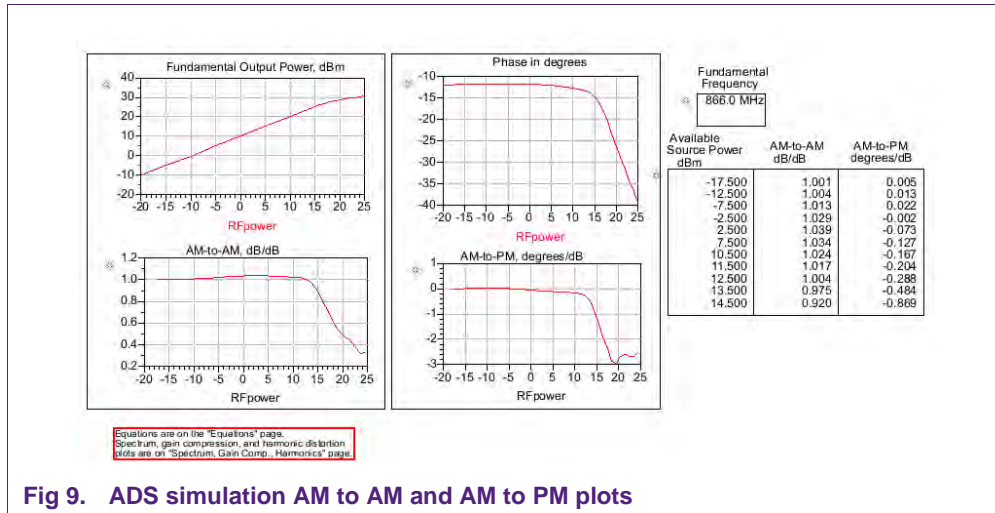

Fig 9. ADS simulation AM to AM and AM to PM plots

Natural behavior of a class AB circuit is the I_{dc} increase over output power. At 1dB compression (28dBm) the $I_{dc} = 133\text{mA}$. Dissipated power in that situation is $8 \times 0.133 = 1.06\text{W}$ which gives an efficiency of 59%.

5.6 Definition of input / source matching circuit

By tuning C2 and L2 the input RF match and gain can be set, results of the simulation see figure 10.

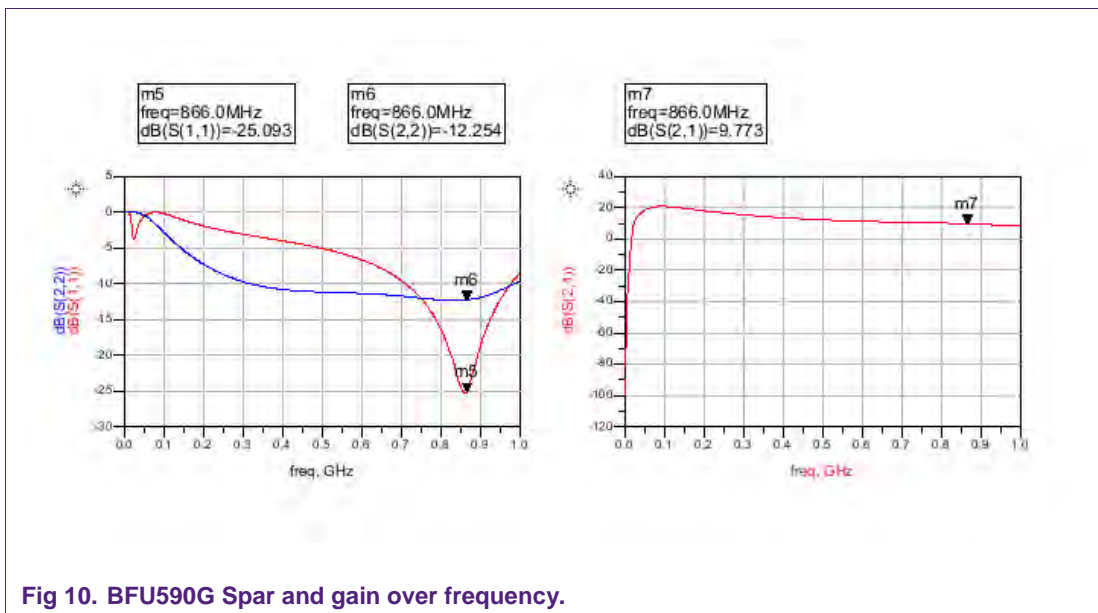

Fig 10. BFU590G Spar and gain over frequency.

S-parameters and gain over frequency.

6. Application circuit

The circuit diagram of the evaluation board is shown in Fig 11 PCB schematic.

6.1 BFU590G 866 MHz ISM PA schematic

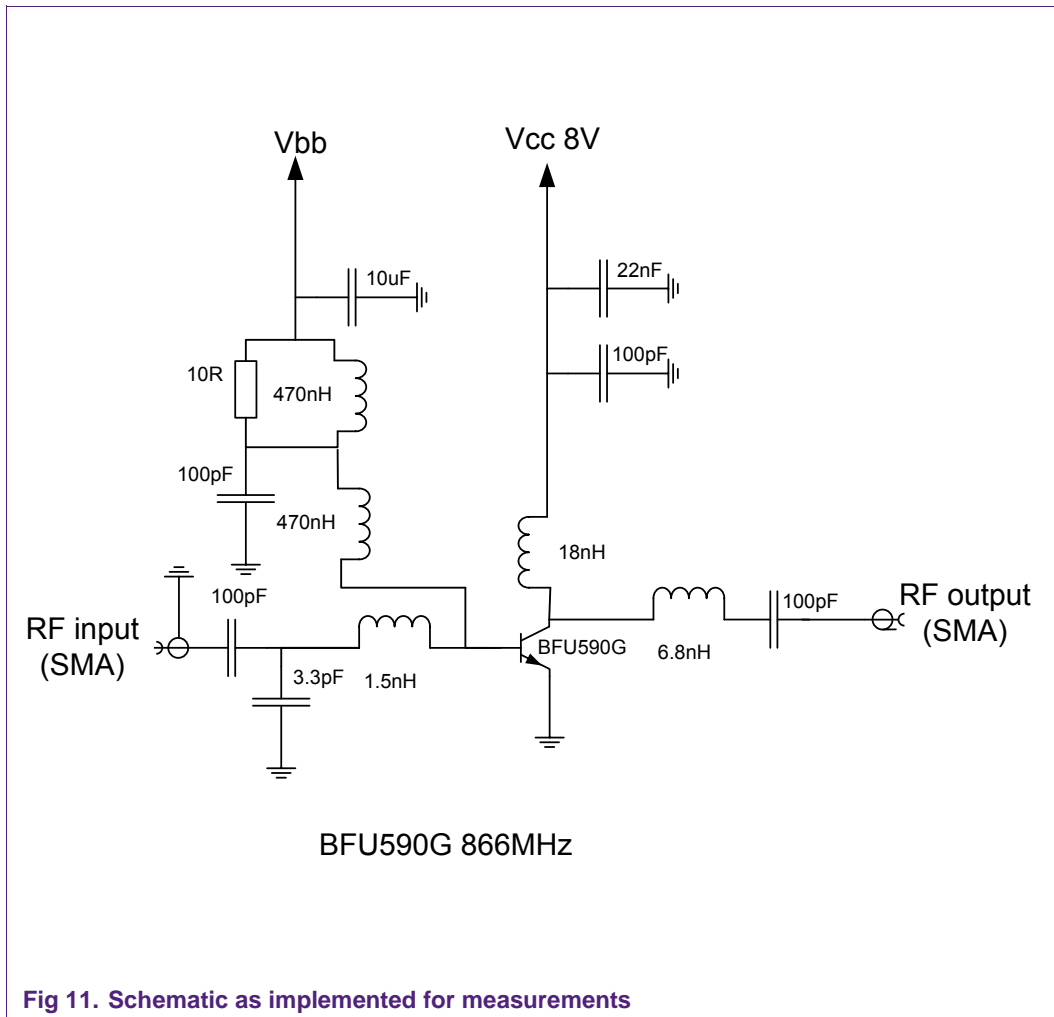

6.2 BFU590G 866 MHz ISM PA PCB drawing

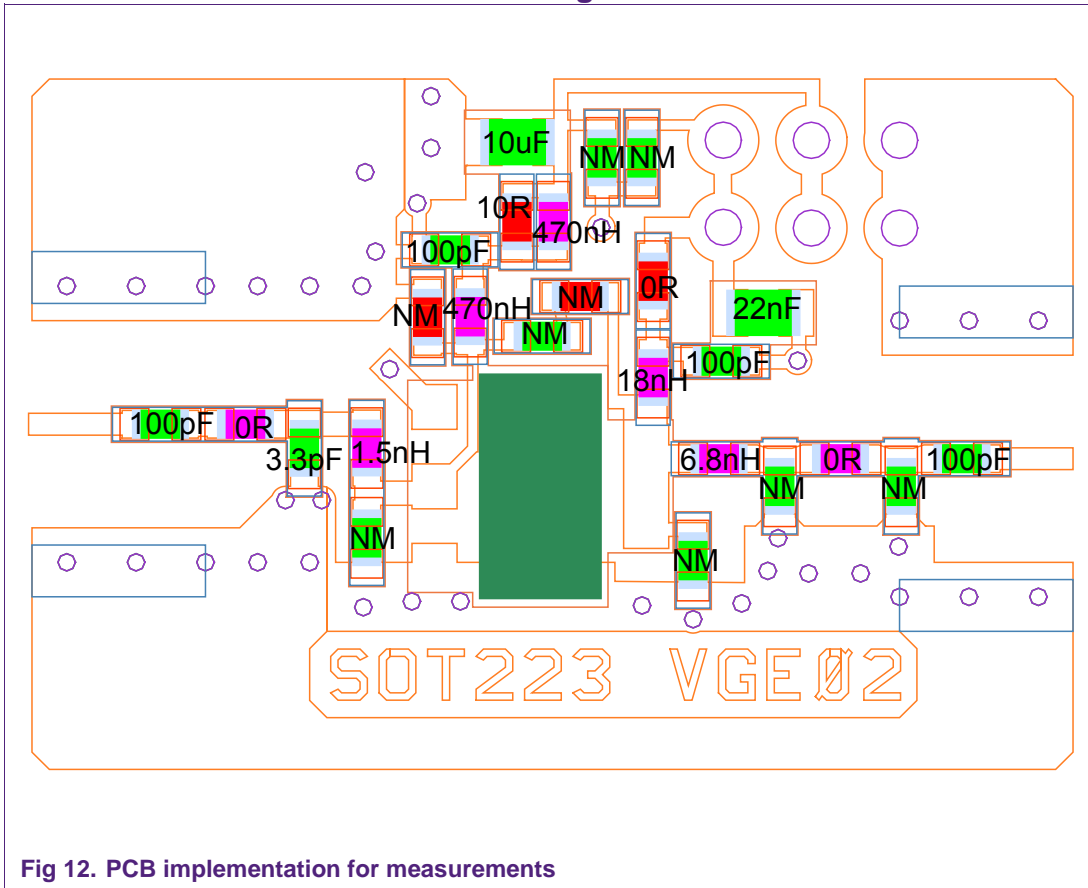

Fig 12. PCB implementation for measurements

Remarks:

0R = SMD jumper

NM = component not mounted.

This layout, as delivered with the Starter kit, accommodates the possibility to implement the biasing as shown in the ADS schematics.

6.3 PCB properties, layer stack

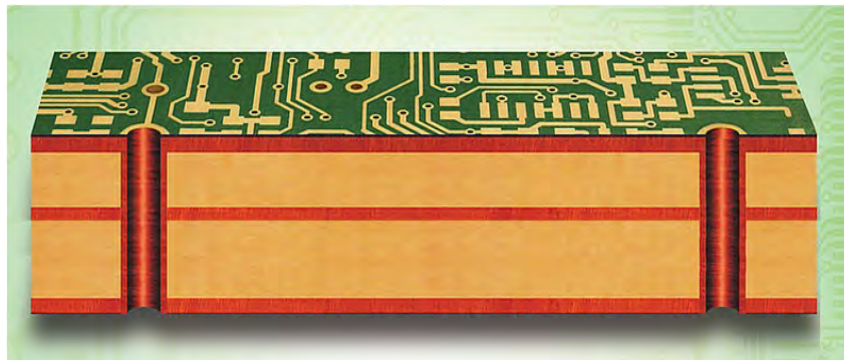

Fig 13. PCB layers used for Evaluation Boards in Starter kit

6.4 Typical PA evaluation board results

Table 2. Typical results measured on the evaluation boards

Operating Frequency is $f = 866$ MHz unless otherwise specified; Temp = 25 °C

Parameter	Symbol	EVB	Unit	Remarks
Supply Voltage	V_{CC}	8	V	
Supply Current	I_{CC}	100	mA	
Power Gain	G_p	10	dB	
Input Return Loss	RL_{in}	-12	dB	
Output Power (P1dB)	P1dB	27	dBm	
Efficiency	η_c	55	%	

Table 3. Bill Of Materials

Value	Description	Footprint	Manufacturer
BFU590G	Transistor	SOT223	NXP Semiconductors
100 pF	Capacitor	0603	Various
3.3 pF	Capacitor	0603	Various
100 pF	Capacitor	0603	Various
10 uF	Capacitor	0805	Various
22 nF	Capacitor	0805	Various
100 pF	Capacitor	0603	Various
1.5 nH	Inductor	0603	Various
470 nH	Resistor	0603	Various
470 nH	Inductor	0603	Various
18 nH	Inductor	0603	Various
6.8 nH	Inductor	0603	Various
10 Ω	Resistor	0603	Various

7. Characterization of PA over temperature and supply voltage

7.1 Gain (S21) = f (freq)

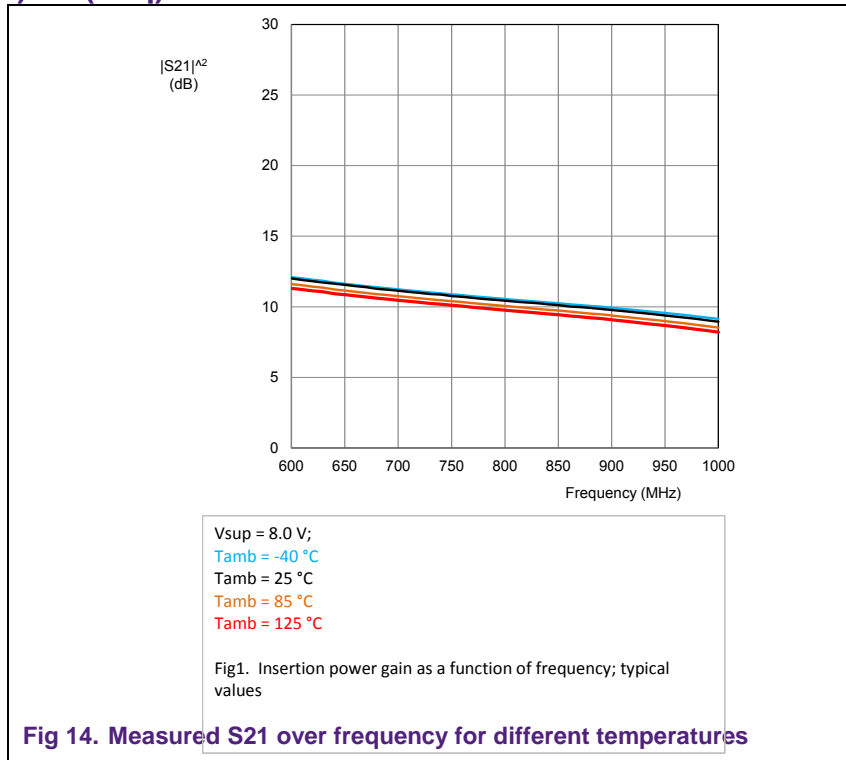

7.2 Input return-loss (S11) = f (freq)

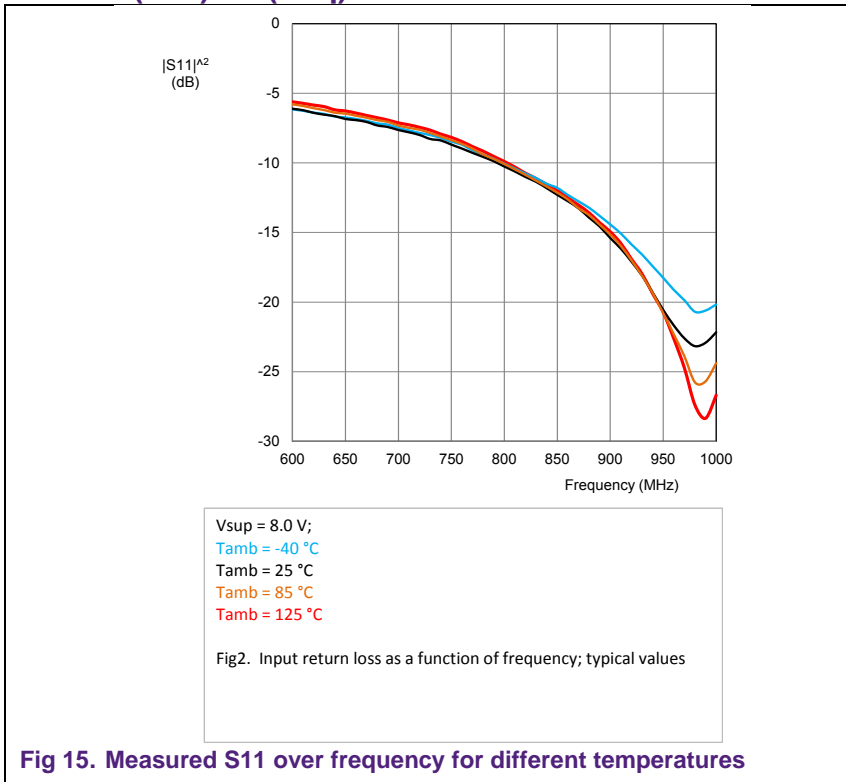

7.3 Output return-loss (S22) = f (freq)

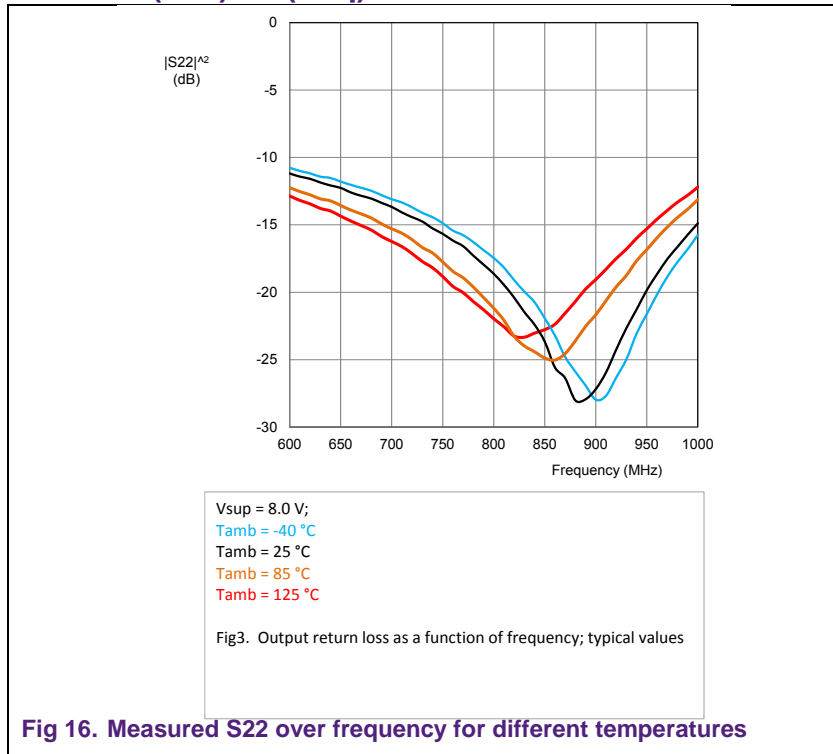

7.4 Isolation (S12) = f (freq)

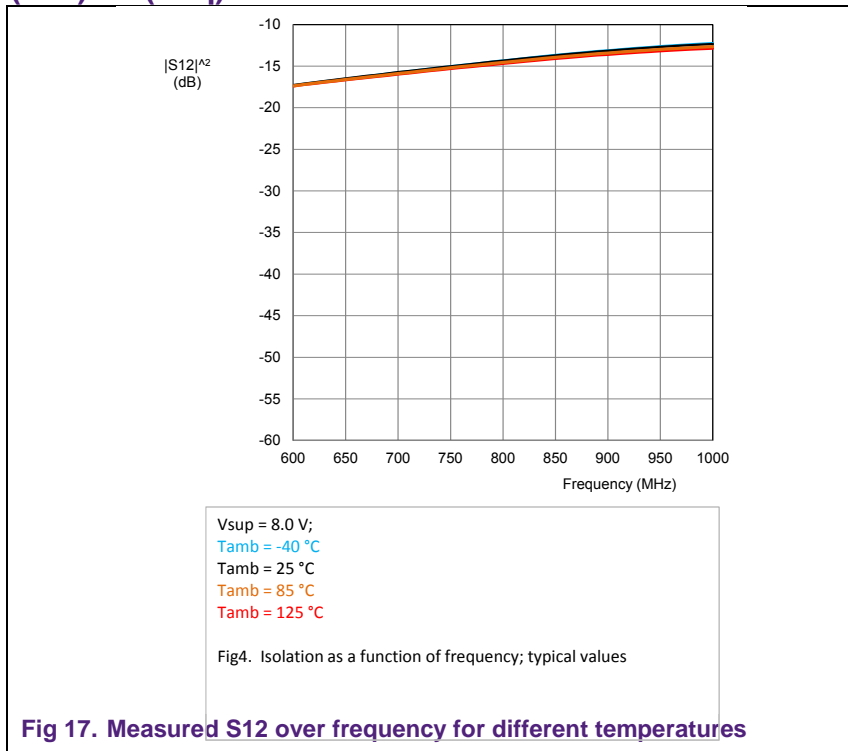

All Sparameters measured at low input power (-40dBm)

7.5 1dB compression and efficiency = f (Tamb)

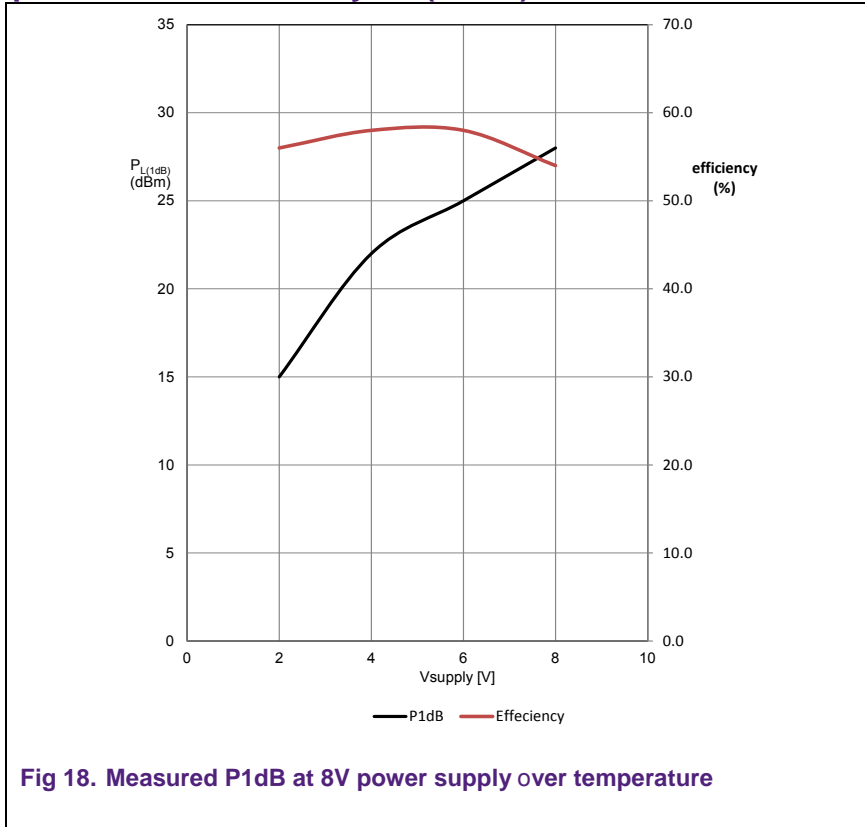

7.6 1dB compression and efficiency = f (Vsupply)

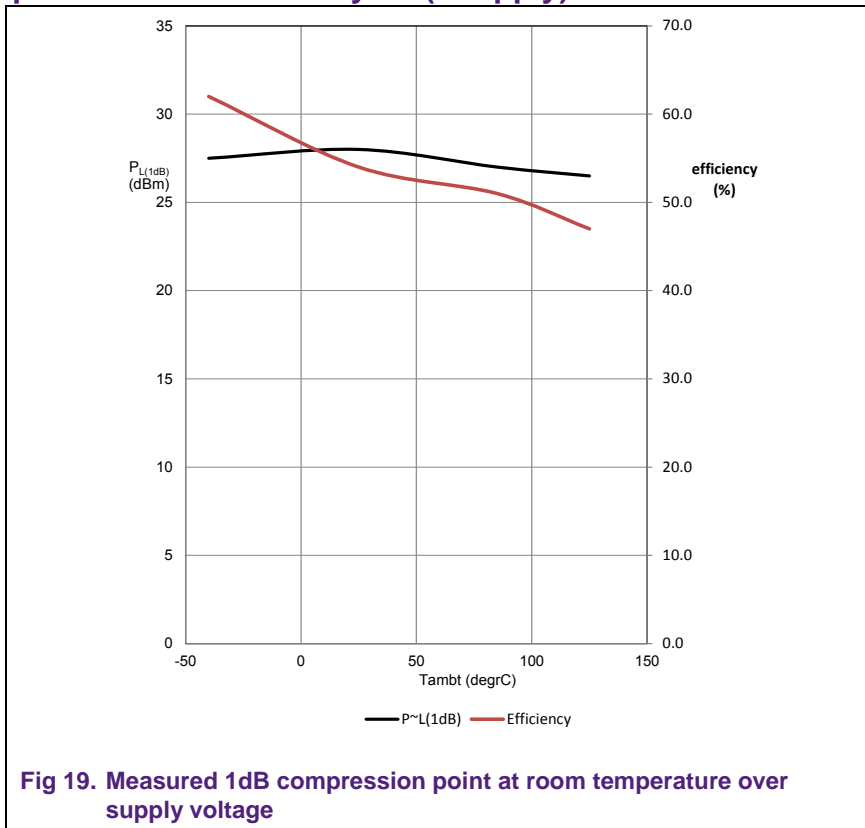

7.7 2 tone IMD and $I_{dc} = f(P_{out})$ for 3 bias currents

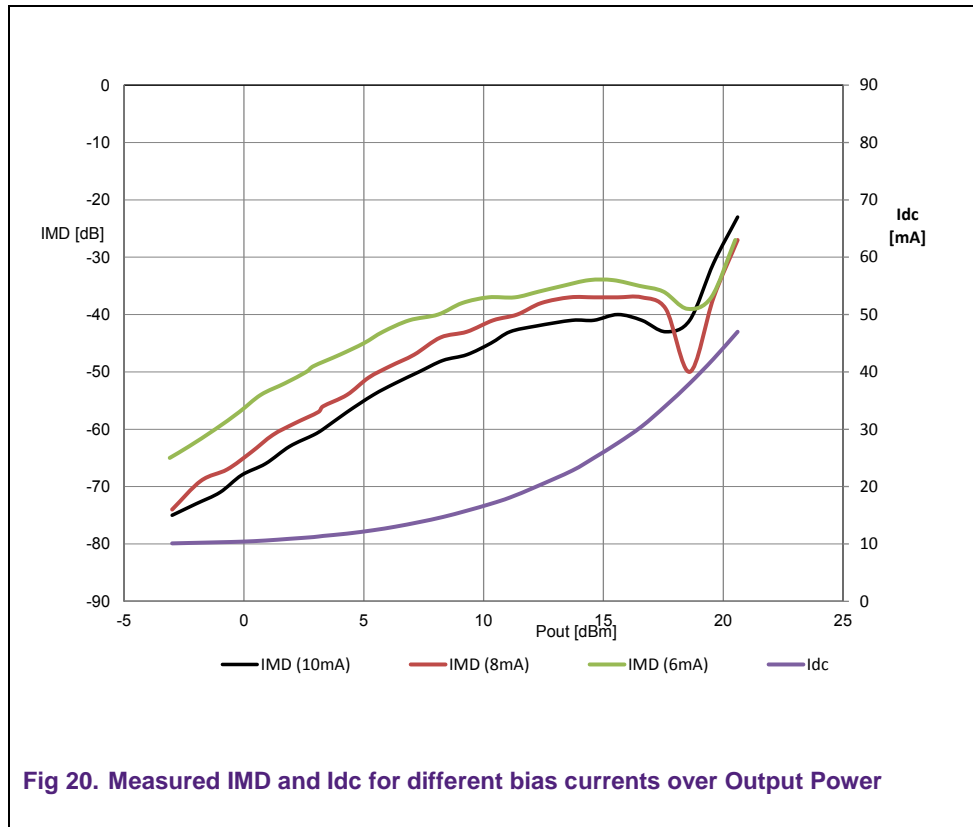

8. Conclusions / recommendations

With the BFU590G transistor a 866 MHz PA design can be implemented with a P1dB of about 27dBm and having a good efficiency of about 55%. Gain is 10dB. The circuit can be used as a base for derivative designs, matching to other frequencies can be done by tuning relevant capacitors and inductors.

For improvements on linearity over output level it could be recommended to set the correct DC biasing current.

This PA can be tuned to other frequencies as well. The presented configuration has been designed for a small bandwidth application.

For wideband power amplifiers a feedback is recommended which can be implemented on the existing board.

9. References

BFU590G datasheet

BFU590G starter-kit (OM7966) User Manual, UM10772

10. Legal information

10.1 Definitions

Draft — The document is a draft version only. The content is still under internal review and subject to formal approval, which may result in modifications or additions. NXP Semiconductors does not give any representations or warranties as to the accuracy or completeness of information included herein and shall have no liability for the consequences of use of such information.

10.2 Disclaimers

Limited warranty and liability — Information in this document is believed to be accurate and reliable. However, NXP Semiconductors does not give any representations or warranties, expressed or implied, as to the accuracy or completeness of such information and shall have no liability for the consequences of use of such information. NXP Semiconductors takes no responsibility for the content in this document if provided by an information source outside of NXP Semiconductors.

In no event shall NXP Semiconductors be liable for any indirect, incidental, punitive, special or consequential damages (including - without limitation - lost profits, lost savings, business interruption, costs related to the removal or replacement of any products or rework charges) whether or not such damages are based on tort (including negligence), warranty, breach of contract or any other legal theory.

Notwithstanding any damages that customer might incur for any reason whatsoever, NXP Semiconductors' aggregate and cumulative liability towards customer for the products described herein shall be limited in accordance with the Terms and conditions of commercial sale of NXP Semiconductors.

Right to make changes — NXP Semiconductors reserves the right to make changes to information published in this document, including without limitation specifications and product descriptions, at any time and without notice. This document supersedes and replaces all information supplied prior to the publication hereof.

Suitability for use — NXP Semiconductors products are not designed, authorized or warranted to be suitable for use in life support, life-critical or safety-critical systems or equipment, nor in applications where failure or malfunction of an NXP Semiconductors product can reasonably be expected to result in personal injury, death or severe property or environmental damage. NXP Semiconductors and its suppliers accept no liability for inclusion and/or use of NXP Semiconductors products in such equipment or applications and therefore such inclusion and/or use is at the customer's own risk.

Applications — Applications that are described herein for any of these products are for illustrative purposes only. NXP Semiconductors makes no representation or warranty that such applications will be suitable for the specified use without further testing or modification.

Customers are responsible for the design and operation of their applications and products using NXP Semiconductors products, and

NXP Semiconductors accepts no liability for any assistance with applications or customer product design. It is customer's sole responsibility to determine whether the NXP Semiconductors product is suitable and fit for the customer's applications and products planned, as well as for the planned application and use of customer's third party customer(s). Customers should provide appropriate design and operating safeguards to minimize the risks associated with their applications and products.

NXP Semiconductors does not accept any liability related to any default, damage, costs or problem which is based on any weakness or default in the customer's applications or products, or the application or use by customer's third party customer(s). Customer is responsible for doing all necessary testing for the customer's applications and products using NXP Semiconductors products in order to avoid a default of the applications and the products or of the application or use by customer's third party customer(s). NXP does not accept any liability in this respect.

Export control — This document as well as the item(s) described herein may be subject to export control regulations. Export might require a prior authorization from national authorities.

Evaluation products — This product is provided on an "as is" and "with all faults" basis for evaluation purposes only. NXP Semiconductors, its affiliates and their suppliers expressly disclaim all warranties, whether express, implied or statutory, including but not limited to the implied warranties of non-infringement, merchantability and fitness for a particular purpose. The entire risk as to the quality, or arising out of the use or performance, of this product remains with customer.

In no event shall NXP Semiconductors, its affiliates or their suppliers be liable to customer for any special, indirect, consequential, punitive or incidental damages (including without limitation damages for loss of business, business interruption, loss of use, loss of data or information, and the like) arising out of the use of or inability to use the product, whether or not based on tort (including negligence), strict liability, breach of contract, breach of warranty or any other theory, even if advised of the possibility of such damages.

Notwithstanding any damages that customer might incur for any reason whatsoever (including without limitation, all damages referenced above and all direct or general damages), the entire liability of NXP Semiconductors, its affiliates and their suppliers and customer's exclusive remedy for all of the foregoing shall be limited to actual damages incurred by customer based on reasonable reliance up to the greater of the amount actually paid by customer for the product or five dollars (US\$5.00). The foregoing limitations, exclusions and disclaimers shall apply to the maximum extent permitted by applicable law, even if any remedy fails of its essential purpose.

10.3 Trademarks

Notice: All referenced brands, product names, service names and trademarks are property of their respective owners.

11. List of figures

Fig 1.	BFU590G evaluation boards.....	4
Fig 2.	Circuitry to set DC bias current	6
Fig 3.	Avoiding low frequency instability.....	7
Fig 4.	ADS design template for PA design	8
Fig 5.	ADS design transistor	9
Fig 6.	ADS simulation DC biasing	9
Fig 7.	ADS simulation for maximum output power, efficiency and gain	10
Fig 8.	ADS simulation over output power	10
Fig 9.	ADS simulation AM to AM and AM to PM plots	11
Fig 10.	BFU590G Spar and gain over frequency.	11
Fig 11.	Schematic as implemented for measurements	12
Fig 12.	PCB implementation for measurements.....	13
Fig 13.	PCB layers used for Evaluation Boards in Starter kit	13
Fig 14.	Measured S21 over frequency for different temperatures	15
Fig 15.	Measured S11 over frequency for different temperatures	15
Fig 16.	Measured S22 over frequency for different temperatures	16
Fig 17.	Measured S12 over frequency for different temperatures	16
Fig 18.	Measured P1dB at 8V power supply over temperature.....	17
Fig 19.	Measured 1dB compression point at room temperature over supply voltage	17
Fig 20.	Measured IMD and Idc for different bias currents over Output Power	18

12. List of tables

Table 1. Customer evaluation kits3
Table 2. Typical results measured on the evaluation boards
..... 14
Table 3. Bill Of Materials 14

13. Contents

1.	Abstract	3
2.	Introduction	3
3.	Requirements	4
4.	Design considerations	4
5.	Design approach	5
5.1	Simulation steps	5
5.2	Implementation / evaluation steps	6
5.3	Setting up the DC bias circuit	6
5.4	Setting up the Simulation circuit in ADS	7
5.5	Setting up the collector load	8
5.6	Definition of input / source matching circuit	11
6.	Application circuit	12
6.1	BFU590G 866 MHz ISM PA schematic	12
6.2	BFU590G 866 MHz ISM PA PCB drawing	13
6.3	PCB properties, layer stack	13
6.4	Typical PA evaluation board results	14
7.	Characterization of PA over temperature and supply voltage	15
7.1	Gain (S21) = f (freq)	15
7.2	Input return-loss (S11) = f (freq)	15
7.3	Output return-loss (S22) = f (freq)	16
7.4	Isolation (S12) = f (freq).....	16
7.5	1dB compression and efficiency = f (Tamb)	17
7.6	1dB compression and efficiency = f (Vsupply)..	17
7.7	2 tone IMD and Idc = f (Pout) for 3 bias currents	18
8.	Conclusions / recommendations	19
9.	References	19
10.	Legal information	20
10.1	Definitions.....	20
10.2	Disclaimers.....	20
10.3	Trademarks	20
11.	List of figures	21
12.	List of tables	22
13.	Contents	23

Please be aware that important notices concerning this document and the product(s) described herein, have been included in the section 'Legal information'.

© NXP B.V. 2014.

All rights reserved.

For more information, visit: <http://www.nxp.com>

For sales office addresses, please send an email to: salesaddresses@nxp.com

Date of release: 16 June 2014

Document identifier: AN11501