

BMx7318: Advanced battery cell controller family designed for EV and ESS with low BOM cost



BMx7318 is advanced analog front-end product designed to monitor battery cells in electrified vehicles (BEV, HEV, PHEV, REX etc.) and energy storage systems (ESS).

The product provides 18 channel cell voltage measurement, integrated current measurement, and up to 12 channel analog voltage measurement. The AIN channels support pack voltage measurement, temperature measurement, and insulation measurement.

The product supports inductive and capacitive isolation daisy chain communication and SPI communication with integrated SPI-to-TPL bridge.

The automotive parts support up to ISO 26262 ASIL C function safety target.

The industrial part supports up to SIL2 safety target.

Key features:

- Typical 0.8mV cell voltage measurement accuracy with ultra-low long-term drift.
- Optimized measurement accuracy 1mV for LPF voltage platform.
- Shared pinout for measurement and balancing, low BOM cost for external filter network.
- Integrated current measurement with external Shunt
- Configurable Gain for flexible Shunt value with $\pm 300\text{mV}$ measurement range
 - High accuracy: offset error $1\mu\text{V}$, gain error 0.3%
- Passive cell balancing with 300mA capability
 - With Timer/Voltage/PWM/Temperature controlling methods
- Up to 12 channel common voltage measurement for temperature measurement
- TPL daisy chain compatible to other BCC products
- SPI communication with SPI2TPL bridge function
- I²C controller for external device, like EEPROM

Target Applications:

- Automotive:
 - Electric vehicle high voltage battery management
 - Electric vehicle 48V battery management
- Industrial:
 - Stationary ESS
 - Commercial ESS
 - Residential ESS
 - Micromobility
 - eBike/eScooter



Main block diagram

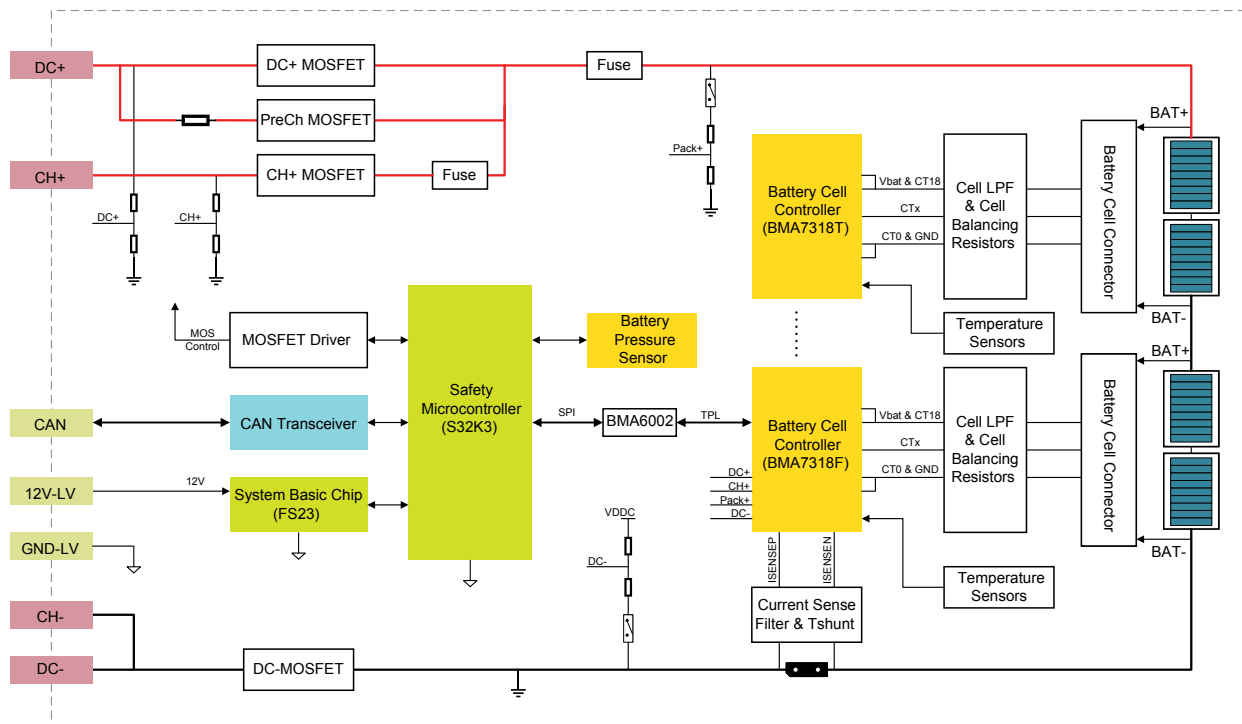

Part Number	Temp Range	Other features	Other features	Package
BMA7318FAIAE	-40°C~125°C	SPI, SPI2TPL	Isense, 10 GPIO	LQFP 64 Pin
BMA7318TAIAE	-40°C~125°C	TPL	Isense, 10 GPIO	LQFP 64 Pin
BMA7318TANAE	-40°C~125°C	TPL	12 GPIO	LQFP 64 Pin
BMA7518SAIAE	-40°C~125°C	SPI	10 GPIO	LQFP 64 Pin
BMI7318TANAE	-40°C~125°C	TPL	12 GPIO	LQFP 64 Pin

[nxp.com/BMx7x18](https://www.nxp.com/BMx7x18)

NXP and the NXP logo are trademarks of NXP B.V. All other product or service names are the property of their respective owners. © 2024 NXP B.V.

Document Number: BMx7318FS REV 0