

RM00230

NTAG 5 link and switch development board - Getting started guide

Rev. 1.0 — 29 April 2020
612810

Reference manual
COMPANY PUBLIC

Document information

Information	Content
Keywords	OM2NTP5332 development board, evaluation board, how to start
Abstract	Document describes how to get started and evaluate NTAG 5 using OM2NTP5332



Revision history

Rev	Date	Description
v.1.0	20200429	First official released version

1 Abbreviations

Table 1. Abbreviations

Acronym	Description
EEPROM	Electrically Erasable Programmable Read-Only Memory
GPIO	General-purpose input/output
I ² C	Inter-Integrated Circuit
NFC	Near field communication
PHDC	Personal Health Device Communication
POR	Power On Reset
PWM	Pulse width modulation
RF	radio frequency
SRAM	Static random-access memory

2 Introduction

This board provides an easy and quick evaluation and development environment for NTAG 5 enabled applications, especially for those leveraging I²C master, I²C slave, GPIO or PWM use cases. A broad selection of software packages is available, which are based on modular examples. These examples can be easily extracted and reused on any other platform. The NTAG 5 link/switch development board can be stacked on single-board computer boards, MCU evaluation boards (e.g. NXP LPCXpresso Boards, NXP Freedom Boards), or be used standalone. Note, the antenna part can be broken-off and replaced by any other antenna to fit the desired application.

2.1 Potential applications

- Read out of data collected in an embedded device (logging data)
- Upload new data in the embedded device (e.g. firmware update of the microcontroller)
- Bidirectional communication with exchange of commands and data (e.g. execute functions in the microcontroller or execute authentication schemes)

3 Getting started

OM2NTP5332 NTAG 5 development board package includes:

Table 2. OM2NTP5332 board contents

Item 1
NTAG 5 development board board

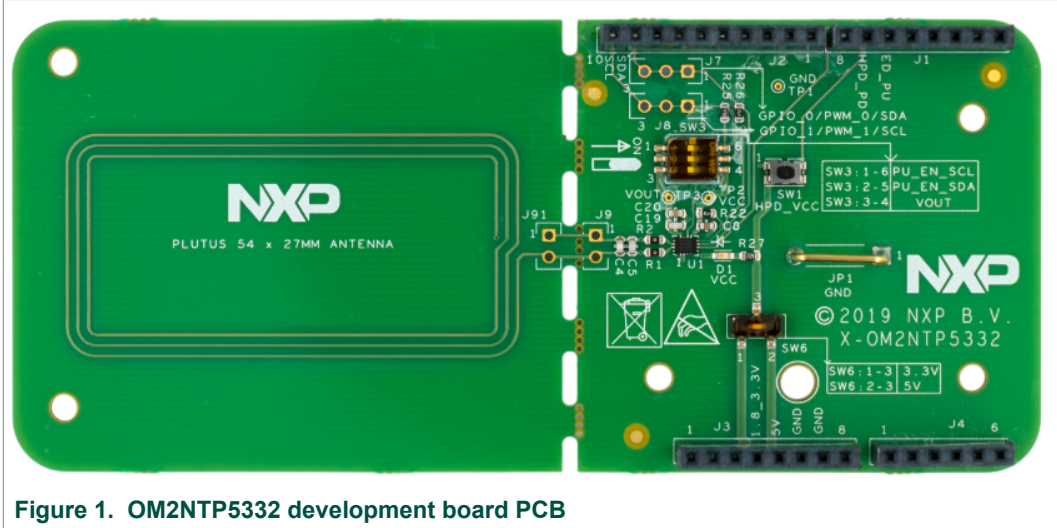

3.1 Hardware description

3.1.1 Connector PINOUT description

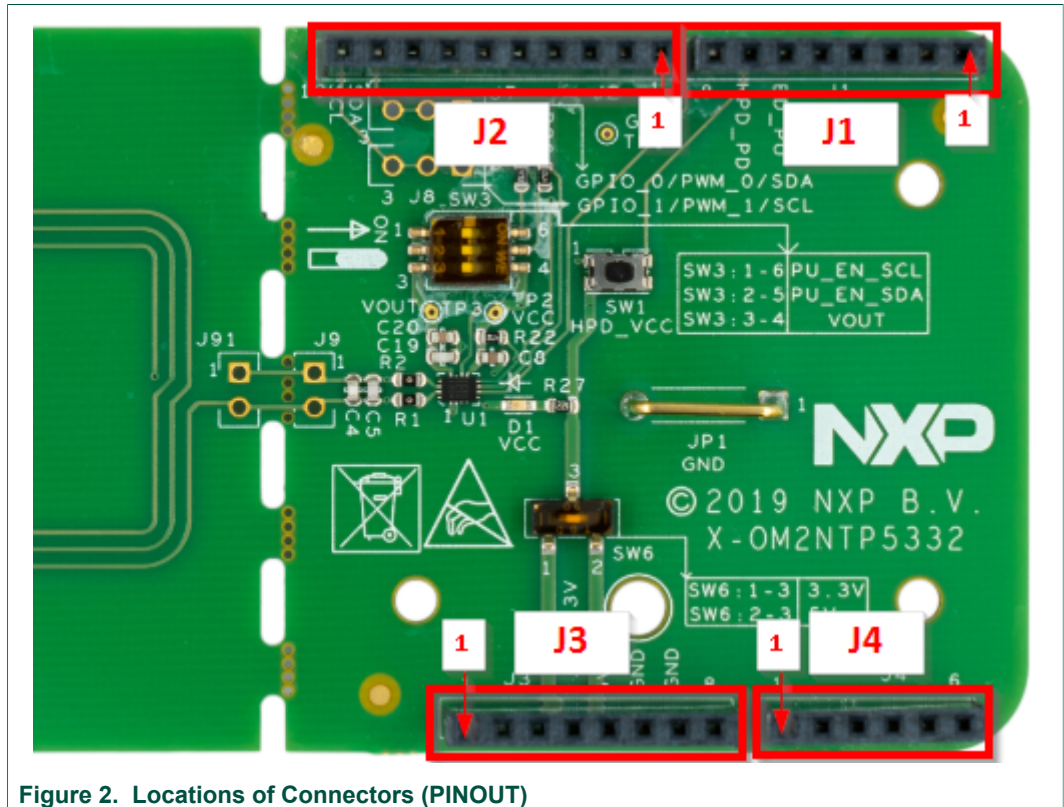

Figure 2. Locations of Connectors (PINOUT)

Table 3. OM2NTP5332 pinout description

Connector: Pin number	Net name	Description
J1:6	ED_PU	Event detection pin (can be configured as PWM0 mirror). Open drain. Pulled up to Vcc by R22 (4.7k Ohm).
J1:7	HPD_PD	Hard Power Down pin. Pulled down to GND by R24 (10 kOhm).
J2:7	GND	Ground
J2:9	SDA	Multiplexed pin: I ² C SDA data line / GPIO1 / PWM1. Can be optionally pulled up to Vcc by switch SW3:2 on position. R26 (4.7 kOhm).
J2:10	SCL	Multiplexed pin: I ² C SCL data line / GPIO0 / PWM0. Can be optionally pulled up to Vcc by switch SW3:1 on position. R25 (4.7 kOhm).
J3:4	P1V8_3V3_BRD	Lower voltage source from underlying board (e.g. MCU board). Usually 3.3 V.
J3:5	P5V0	Higher voltage source from underlying board (e.g. MCU board). Usually 5 V.
J3:6	GND	Ground
J3:7	GND	Ground

3.1.2 Switches and other components description

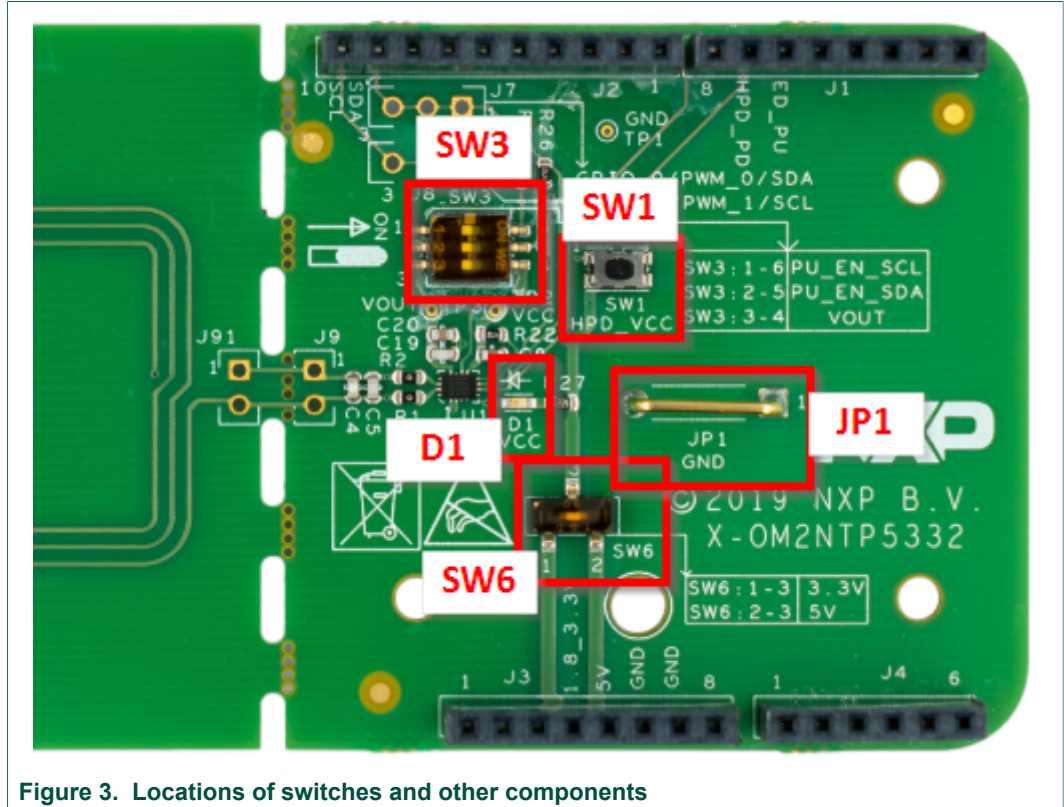

Figure 3. Locations of switches and other components

Table 4. OM2NTP5332 switches and other components description

Connector: Pin number	Net name / Options	Description
SW3	1. 1-6: PU_EN_SCL 2. 2-5: PU_EN_SDA 3. 3-4: VOUT	1. With ON position, Pull up R25 engaged. 2. With ON position, Pull up R26 engaged 3. With ON position, NTAG 5's VOUT connected to VCC. (a must for energy harvesting)
SW1	HPD_VCC	When HPD is pulled to VCC, NTAG 5 enters High Power-down mode. When released, NTAG 5 exits from HPD mode. Can be used as NTAG 5 reset. For more details on HPD mode, see refer to [datasheet].
SW6	1. 1.8 - 3.3 V 2. 5 V	VCC chooser. It only connects voltage from underlying board or source to the NTAG 5 and whole PCB.
D1	D1	Green LED
JP1	GND	Jumper for easy access to GND.

3.1.3 Schematics

Please refer to [SCH-45997].

4 Optional hardware which is supported for development

This chapter lists optional supported hardware which is NOT included in the board. It eases evaluation and enables faster integration or portation to other similar devices. Optional hardware needs to be ordered separately.

Table 5. Supported optional hardware (NOT included in the board). Needs to be ordered separately.

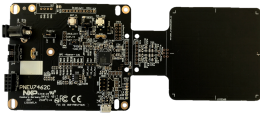
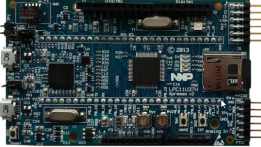
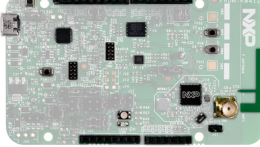
	Item 1	Item 2	Item 3	Item 4
Description	NFC mobile	RF (ISO15693) reader	MCU development board	MCU development board
Purpose	Developing iOS or Android based applications	Developing VCD (RF, NFC) applications. Either FW or higher software layer.	Developing MCU based I ² C Slave, GPIO, PWM use cases.	Developing MCU based I ² C Slave, GPIO, PWM use cases.
Picture		 <p>Figure 4. pnev7462c reader development board</p>	 <p>Figure 5. LPCXpresso board for LPC11U37H</p>	 <p>Figure 6. FRDM-KW41Z development board</p>
Chapter in this document	[Section 4.1]	[Section 4.2]	[Section 4.3]	[Section 4.3]
Buying options		Via NXP's distribution or through nxp.com.	Via NXP's distribution or through nxp.com.	Via NXP's distribution or through nxp.com.

4.1 Mobile NFC application development

Developing iOS and Android-based applications.

Hardware:

1. Device with integrated NFC.

Software:

1. TapLinx (Android only) (mifare.net)
2. Use cases examples using native Android NFC [SW5870]
3. iOS Apps development quick startup guide [ANxx]

Additional documentation:

- NTAG 5 configuration from RF interface
- NFC Forum Type 5 Tag configuration: [[NFC Forum specification, Type 5 Tag](#)]
- NFC Forum NDEF: [[NFC Forum specification, Tag NDEF Exchange Protocol - Technical Specification Version](#)]
- I²C Master: [[AN12368 - NTAG 5 Link I2C Master mode](#)]
- I²C Slave: [[AN12364 - NTAG 5 Bidirectional data exchange](#)]
- Pass-through mode: [[AN12364 - NTAG 5 Bidirectional data exchange](#)]
- PHDC data transfer: [[AN12364 - NTAG 5 Bidirectional data exchange](#)], [[NFC Forum Personal Health Care Devices \(PHDC\) specification](#)]
- Energy harvesting: [[AN11201 - NTAG 5 How to use energy harvesting](#)]

- GPIO: [[AN11203 - NTAG 5 Use of PWM, GPIO and Event detection](#)]
- PWM: [[AN11203 - NTAG 5 Use of PWM, GPIO and Event detection](#)]
- Event detection: [[AN11203 - NTAG 5 Use of PWM, GPIO and Event detection](#)]
- Low-power modes: [[AN12429 - NTAG 5 Stand-by and Hard Power down modes of operation](#)]
- Protecting User memory and features, Security: [[AN12366 - NTAG 5 Memory Configuration and Scalable Security](#)]

4.2 RF (ISO15693) reader development

Easy RF evaluation of NTAG 5 features. Also for developing VCD (RF, NFC) applications, either FW or higher layer software.

Hardware:

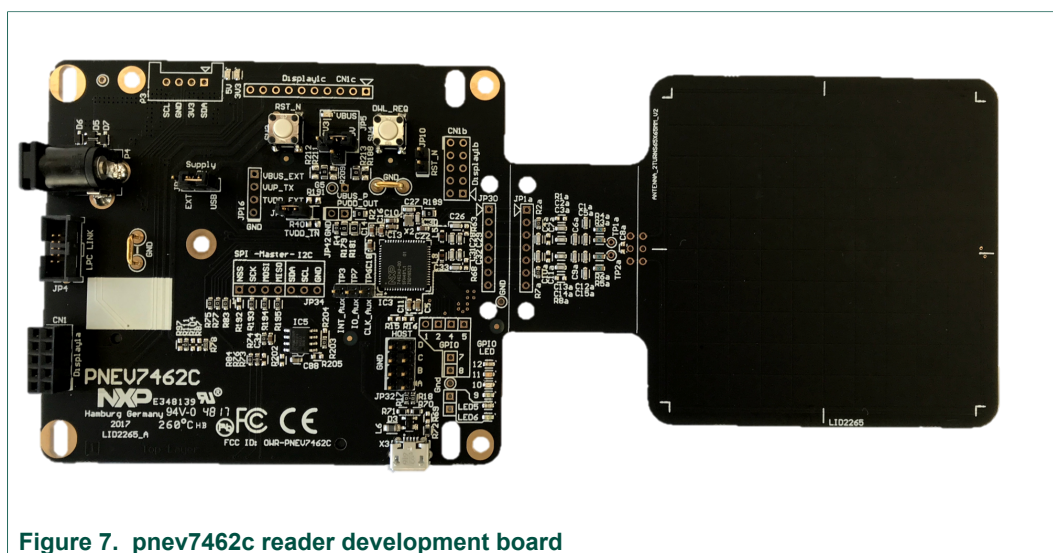

Figure 7. pnev7462c reader development board

Software:

- GUI
 - RFIDDiscover ([DocStore](#))
 - NFCCockpit ([nxp.com webpage](#))
- Firmware: NFC Reader Library ([DocStore](#))
- .NET: NXP Reader Library ([DocStore](#))

Additional Documentation:

- NTAG 5 configuration from RF interface
- I²C Master: [AN12368 - NTAG 5 Link I2C Master mode](#)
- I²C Slave: [AN12364 - NTAG 5 Bidirectional data exchange](#)
- Pass-through mode: [AN12364 - NTAG 5 Bidirectional data exchange](#)
- PHDC data transfer: [AN12364 - NTAG 5 Bidirectional data exchange](#)
- Energy harvesting: [AN11201 - NTAG 5 How to use energy harvesting](#)
- GPIO: [AN11203 - NTAG 5 Use of PWM, GPIO and Event detection](#)
- PWM: [AN11203 - NTAG 5 Use of PWM, GPIO and Event detection](#)
- Event detection: [AN11203 - NTAG 5 Use of PWM, GPIO and Event detection](#)

4.3 MCU FW development

Easy I²C evaluation of NTAG 5 features. Also for Developing MCU firmware-based energy harvesting, I²C Slave, GPIO, PWM use cases.

4.3.1 LPC11U37H MCU based

Hardware:

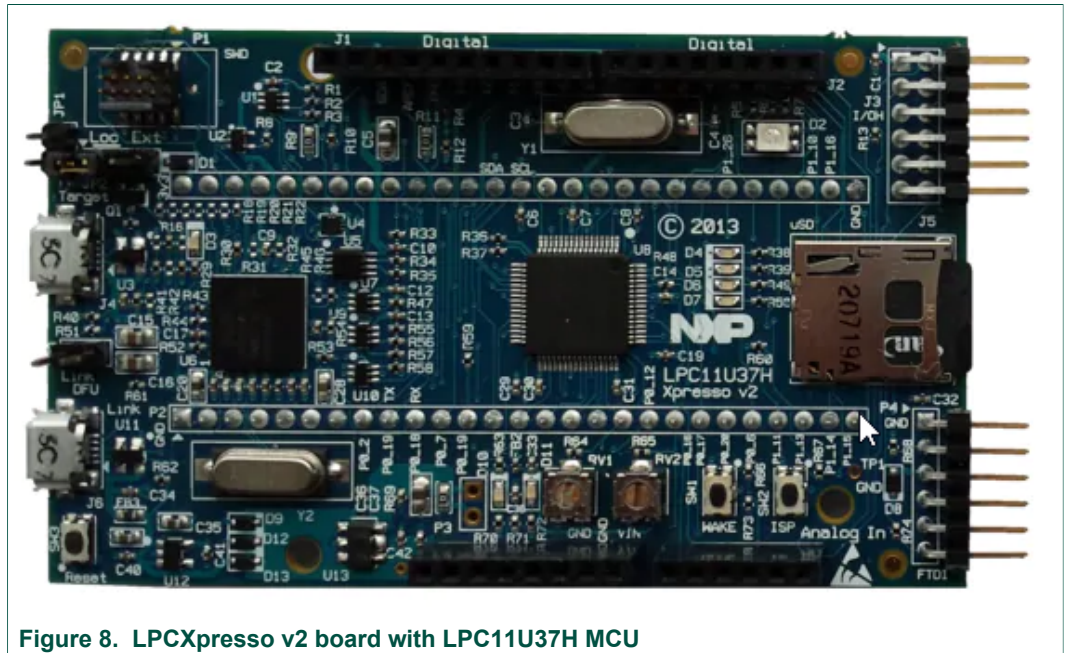

Figure 8. LPCXpresso v2 board with LPC11U37H MCU

Software:

- Use cases Code examples [SW6090]:
 - GPIO
 - PWM
 - Pass-through mode
- GUI - NTAG 5 Cockpit (easy I²C access)

Documentation:

- NTAG 5 configuration from I²C interface
- NFC Forum Type 5 Tag configuration: [NFC Forum specification, Type 5 Tag]
- NFC Forum NDEF: [NFC Forum specification, Tag NDEF Exchange Protocol - Technical Specification Version]
- I²C Slave: [AN12364 - NTAG 5 Bidirectional data exchange]
- Pass-through mode: [AN12364 - NTAG 5 Bidirectional data exchange]
- PHDC data transfer: [AN12364 - NTAG 5 Bidirectional data exchange], [NFC Forum Personal Health Care Devices (PHDC) specification]
- Energy harvesting: [AN11201 - NTAG 5 How to use energy harvesting]
- GPIO: [AN11203 - NTAG 5 Use of PWM, GPIO and Event detection]
- PWM: [AN11203 - NTAG 5 Use of PWM, GPIO and Event detection]
- Event detection: [AN11203 - NTAG 5 Use of PWM, GPIO and Event detection]
- NTAG 5 middleware porting guide: [RM00229 - NTAG 5 Middleware portation guide]

5 References

- [1] NTA5332 - NTAG 5 boost, NFC Forum-compliant I²C bridge for tiny devices, doc.no. 5475xx
<https://www.nxp.com/docs/en/data-sheet/NTA5332.pdf>
- [2] NFC Forum specification, Type 5 Tag - Technical Specification Version 1.0 2018-04-27 [T5T] NFC Forum™
<https://nfc-forum.org/product-category/specification/>
- [3] NFC Forum specification, Tag NDEF Exchange Protocol - Technical Specification Version 1.0 2019-04-24 [TNEP] NFC Forum™
<https://nfc-forum.org/our-work/specifications-and-application-documents/specifications/nfc-forum-candidate-technical-specifications/>
- [4] NFC Forum Personal Health Care Devices (PHDC) specification
<https://nfc-forum.org/product-category/specification/>
- [5] AN11203 - NTAG 5 Use of PWM, GPIO and Event detection, doc.no. 5302xx
<https://www.nxp.com/docs/en/application-note/AN11203.pdf>
- [6] AN12364 - NTAG 5 Bidirectional data exchange, doc.no. 5303xx
<https://www.nxp.com/docs/en/application-note/AN12364.pdf>
- [7] AN11201 - NTAG 5 How to use energy harvesting, doc.no. 5304xx
<https://www.nxp.com/docs/en/application-note/AN11201.pdf>
- [8] AN12366 - NTAG 5 Memory Configuration and Scalable Security, doc.no. 5305xx
<https://www.nxp.com/docs/en/application-note/AN12366.pdf>
- [9] AN12368 - NTAG 5 Link I²C Master mode, doc.no. 5306xx
<https://www.nxp.com/docs/en/application-note/AN12368.pdf>
- [10] AN12429 - NTAG 5 Stand-by and Hard Power down modes of operation
<https://www.nxp.com/docs/en/application-note/AN12429.pdf>
- [11] SW6090 - NTAG 5 Development kit source code and library for LPC microcontrollers. Contains NTAG 5 middleware library, Pass-through mode, GPIO and PWM examples
<https://www.nxp.com/downloads/en/nxp/software/SW6090.zip>
- [12] SW5870 - NTAG 5 Development kit Android application source code. NTAG 5 Development kit Android application source code
<https://www.nxp.com/downloads/en/nxp/software/SW5870.zip>
- [13] SCH-45997 - OM2NTP5332 NTAG 5 link - Development Board Schematic
<https://www.nxp.com/docs/en/supporting-information/SCH-45997.pdf>
- [14] RM00229 - NTAG 5 Middleware portation guide, doc.no.

6 Legal information

6.1 Definitions

Draft — The document is a draft version only. The content is still under internal review and subject to formal approval, which may result in modifications or additions. NXP Semiconductors does not give any representations or warranties as to the accuracy or completeness of information included herein and shall have no liability for the consequences of use of such information.

6.2 Disclaimers

Limited warranty and liability — Information in this document is believed to be accurate and reliable. However, NXP Semiconductors does not give any representations or warranties, expressed or implied, as to the accuracy or completeness of such information and shall have no liability for the consequences of use of such information. NXP Semiconductors takes no responsibility for the content in this document if provided by an information source outside of NXP Semiconductors. In no event shall NXP Semiconductors be liable for any indirect, incidental, punitive, special or consequential damages (including - without limitation - lost profits, lost savings, business interruption, costs related to the removal or replacement of any products or rework charges) whether or not such damages are based on tort (including negligence), warranty, breach of contract or any other legal theory. Notwithstanding any damages that customer might incur for any reason whatsoever, NXP Semiconductors' aggregate and cumulative liability towards customer for the products described herein shall be limited in accordance with the Terms and conditions of commercial sale of NXP Semiconductors.

Right to make changes — NXP Semiconductors reserves the right to make changes to information published in this document, including without limitation specifications and product descriptions, at any time and without notice. This document supersedes and replaces all information supplied prior to the publication hereof.

Suitability for use — NXP Semiconductors products are not designed, authorized or warranted to be suitable for use in life support, life-critical or safety-critical systems or equipment, nor in applications where failure or malfunction of an NXP Semiconductors product can reasonably be expected to result in personal injury, death or severe property or environmental damage. NXP Semiconductors and its suppliers accept no liability for inclusion and/or use of NXP Semiconductors products in such equipment or applications and therefore such inclusion and/or use is at the customer's own risk.

Applications — Applications that are described herein for any of these products are for illustrative purposes only. NXP Semiconductors makes no representation or warranty that such applications will be suitable for the specified use without further testing or modification. Customers are responsible for the design and operation of their applications and products using NXP Semiconductors products, and NXP Semiconductors accepts no liability for any assistance with applications or customer product design. It is customer's sole responsibility to determine whether the NXP Semiconductors product is suitable and fit for the customer's applications and products planned, as well as for the planned application and use of customer's third party customer(s). Customers should provide appropriate design and operating safeguards to minimize the risks associated with their applications and products. NXP Semiconductors does not accept any liability related to any default, damage, costs or problem which is based on any weakness or default in the customer's applications or products, or the application or use by customer's third party customer(s). Customer is responsible for doing all necessary testing for the customer's applications and products using NXP Semiconductors products in order to avoid a default of the applications and the products or of the application or use by customer's third party customer(s). NXP does not accept any liability in this respect.

Export control — This document as well as the item(s) described herein may be subject to export control regulations. Export might require a prior authorization from competent authorities.

Non-automotive qualified products — Unless this data sheet expressly states that this specific NXP Semiconductors product is automotive qualified, the product is not suitable for automotive use. It is neither qualified nor tested in accordance with automotive testing or application requirements. NXP Semiconductors accepts no liability for inclusion and/or use of non-automotive qualified products in automotive equipment or applications. In the event that customer uses the product for design-in and use in automotive applications to automotive specifications and standards, customer (a) shall use the product without NXP Semiconductors' warranty of the product for such automotive applications, use and specifications, and (b) whenever customer uses the product for automotive applications beyond NXP Semiconductors' specifications such use shall be solely at customer's own risk, and (c) customer fully indemnifies NXP Semiconductors for any liability, damages or failed product claims resulting from customer design and use of the product for automotive applications beyond NXP Semiconductors' standard warranty and NXP Semiconductors' product specifications.

Evaluation products — This product is provided on an "as is" and "with all faults" basis for evaluation purposes only. NXP Semiconductors, its affiliates and their suppliers expressly disclaim all warranties, whether express, implied or statutory, including but not limited to the implied warranties of non-infringement, merchantability and fitness for a particular purpose. The entire risk as to the quality, or arising out of the use or performance, of this product remains with customer. In no event shall NXP Semiconductors, its affiliates or their suppliers be liable to customer for any special, indirect, consequential, punitive or incidental damages (including without limitation damages for loss of business, business interruption, loss of use, loss of data or information, and the like) arising out of the use of or inability to use the product, whether or not based on tort (including negligence), strict liability, breach of contract, breach of warranty or any other theory, even if advised of the possibility of such damages. Notwithstanding any damages that customer might incur for any reason whatsoever (including without limitation, all damages referenced above and all direct or general damages), the entire liability of NXP Semiconductors, its affiliates and their suppliers and customer's exclusive remedy for all of the foregoing shall be limited to actual damages incurred by customer based on reasonable reliance up to the greater of the amount actually paid by customer for the product or five dollars (US\$5.00). The foregoing limitations, exclusions and disclaimers shall apply to the maximum extent permitted by applicable law, even if any remedy fails of its essential purpose.

Translations — A non-English (translated) version of a document is for reference only. The English version shall prevail in case of any discrepancy between the translated and English versions.

Security — While NXP Semiconductors has implemented advanced security features, all products may be subject to unidentified vulnerabilities. Customers are responsible for the design and operation of their applications and products to reduce the effect of these vulnerabilities on customer's applications and products, and NXP Semiconductors accepts no liability for any vulnerability that is discovered. Customers should implement appropriate design and operating safeguards to minimize the risks associated with their applications and products.

6.3 Licenses

Purchase of NXP ICs with NFC technology

Purchase of an NXP Semiconductors IC that complies with one of the Near Field Communication (NFC) standards ISO/IEC 18092 and ISO/IEC 21481 does not convey an implied license under any patent right infringed by implementation of any of those standards. Purchase of NXP Semiconductors IC does not include a license to any NXP patent (or other IP right) covering combinations of those products with other products, whether hardware or software.

6.4 Trademarks

Notice: All referenced brands, product names, service names and trademarks are the property of their respective owners.

I²C-bus — logo is a trademark of NXP B.V.

NTAG — is a trademark of NXP B.V.

Tables

Tab. 1.	Abbreviations	3	Tab. 5.	Supported optional hardware (NOT included in the board). Needs to be ordered separately.	8
Tab. 2.	OM2NTP5332 board contents	5			
Tab. 3.	OM2NTP5332 pinout description	6			
Tab. 4.	OM2NTP5332 switches and other components description	7			

Figures

Fig. 1.	OM2NTP5332 development board PCB	5	Fig. 6.	FRDM-KW41Z development board	8
Fig. 2.	Locations of Connectors (PINOUT)	6	Fig. 7.	pnev7462c reader development board	9
Fig. 3.	Locations of switches and other components	7	Fig. 8.	LPCXpresso v2 board with LPC11U37H	
Fig. 4.	pnev7462c reader development board	8		MCU	10
Fig. 5.	LPCXpresso board for LPC11U37H	8			

Contents

1 **Abbreviations** 3

2 **Introduction** 4

2.1 Potential applications4

3 **Getting started** 5

3.1 Hardware description6

3.1.1 Connector PINOUT description 6

3.1.2 Switches and other components description7

3.1.3 Schematics 7

4 **Optional hardware which is supported for development** 8

4.1 Mobile NFC application development 8

4.2 RF (ISO15693) reader development 9

4.3 MCU FW development 10

4.3.1 LPC11U37H MCU based 10

5 **References** 11

6 **Legal information** 12

Please be aware that important notices concerning this document and the product(s) described herein, have been included in section 'Legal information'.

© NXP B.V. 2020.

All rights reserved.

For more information, please visit: <http://www.nxp.com>

For sales office addresses, please send an email to: salesaddresses@nxp.com

Date of release: 29 April 2020
 Document identifier: RM00230
 Document number: 612810